

Kriptografi Visual, Teori dan Aplikasinya (Bag. 1)

Visual
Cryptography

Oleh:
Rinaldi M

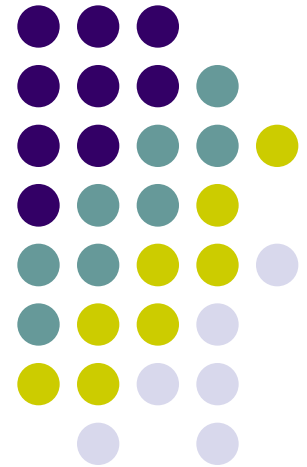

Sebuah cerita...

Ada seorang kepala perompak. Dia mempunyai sebuah gambar peta rahasia yang berisi petunjuk harta karun. Dia ingin membagi gambar peta itu kepada 6 orang anak buahnya, namun untuk merekonstruksi gambar peta itu dibutuhkan sedikitnya 3 bagian gambar. Bagaimana caranya?

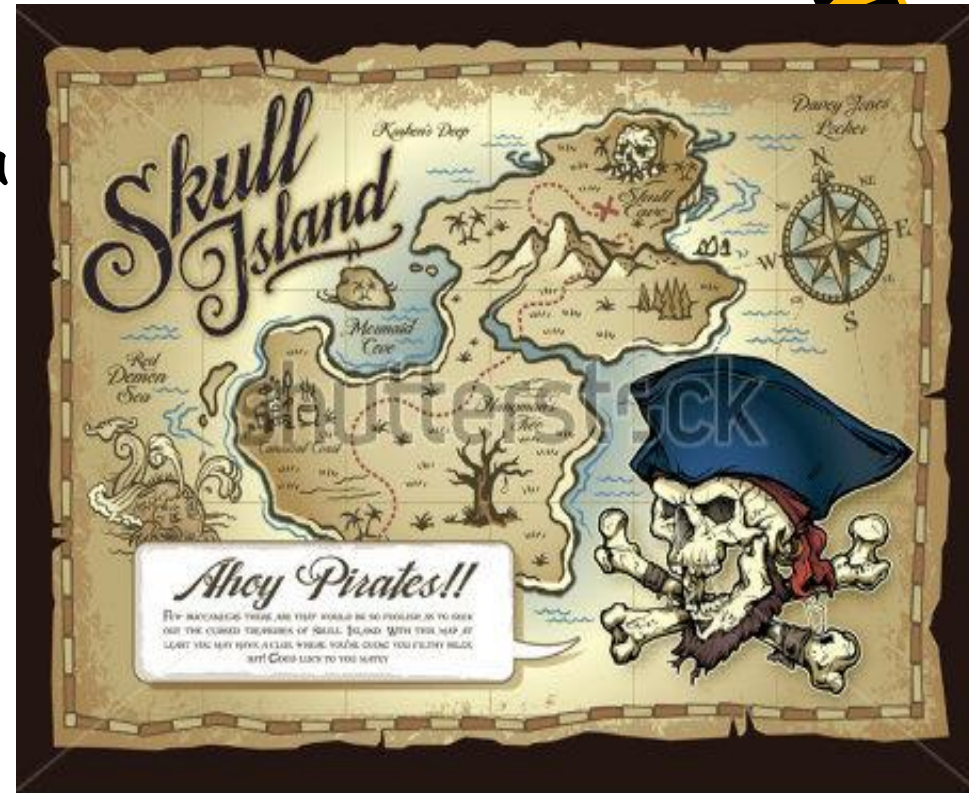

www.shutterstock.com · 90606391



Solusi: **Visual Cryptography!!!!**



Visual

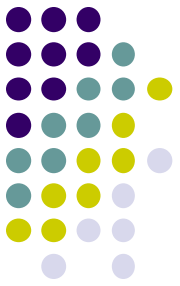

- Apapun yang dipersepsi oleh indra penglihatan



- Informasi visual: teks, gambar, video, animasi, object 3D



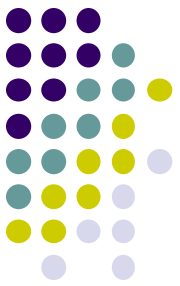

- Teks

A Quick Brown Fox Jumps Over The Lazy Dog 0123456789

A Quick Brown Fox Jumps Over The Lazy Dog 0123456789

A Quick Brown Fox Jumps Over The Lazy Dog 0123456789

A Quick Brown Fox Jumps Over The Lazy Dog 0123456789

A Quick Brown Fox Jumps Over The Lazy Dog 0123456789

A Quick Brown Fox Jumps Over The Lazy Dog 0123456789

A Quick Brown Fox Jumps Over The Lazy Dog 0123456789

A Quick Brown Fox Jumps Over The Lazy Dog 0123456789

A Quick Brown Fox Jumps Over The Lazy Dog 0123456789

A Quick Brown Fox Jumps Over The Lazy Dog 0123456789

A Quick Brown Fox Jumps Over The Lazy Dog 0123456789

A Quick Brown Fox Jumps Over The Lazy Dog 0123456789



- Gambar (citra)



"Sebuah gambar bermakna lebih dari seribu kata"
(A picture is more than a thousand words)



- Video

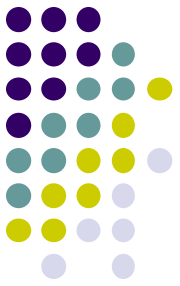

- Animasi

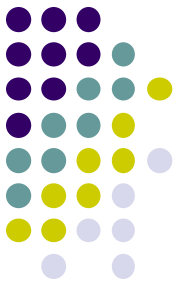

- Object 3D

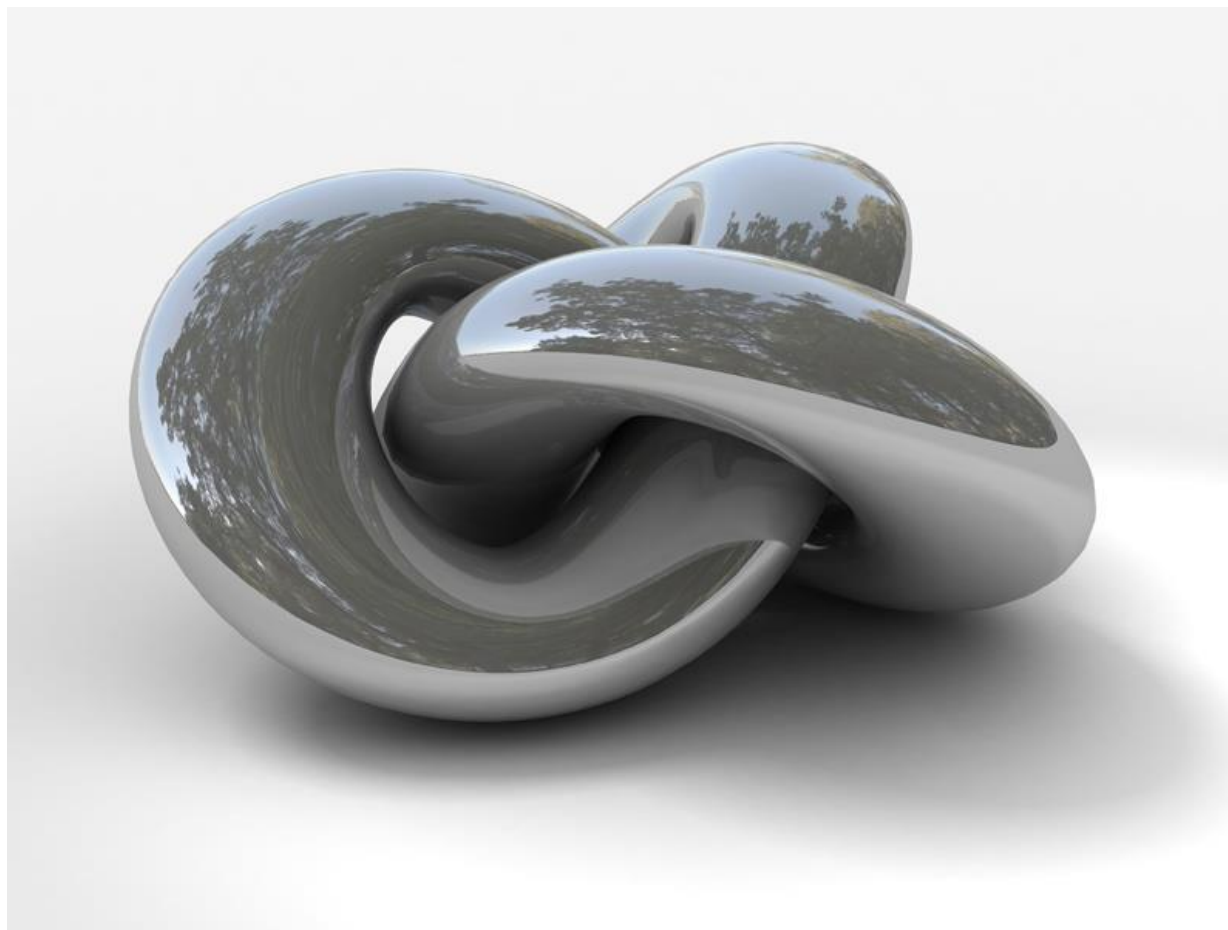

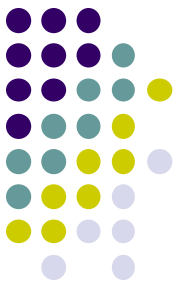

Visual Cryptography

- Teknik kriptografi yang *mengenkripsi* informasi visual dengan suatu cara sehingga *dekripsi* cukup dilakukan dengan mempersepsi informasi menggunakan indra penglihatan (mata).

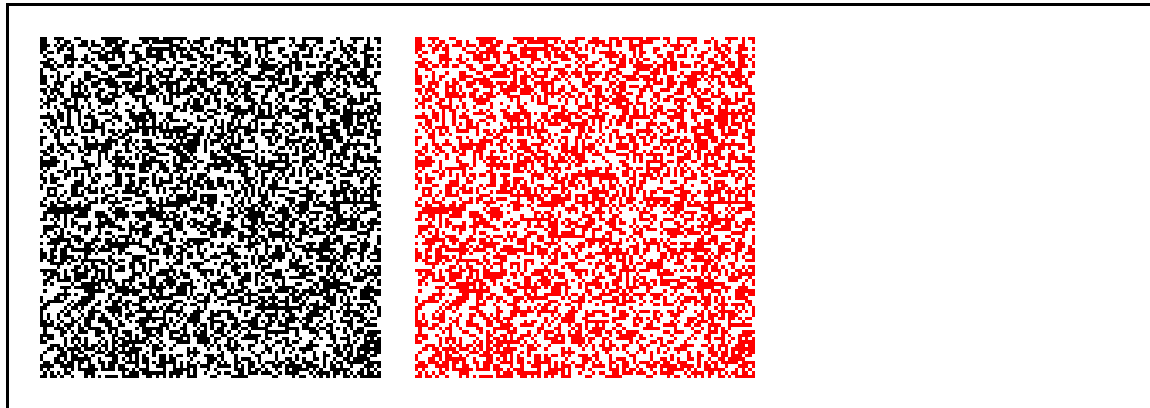

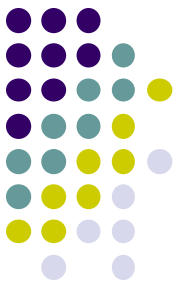

- Diperkenalkan oleh Moni Naor dan Adi Shamir dalam makalah berjudul “*Visual Cryptography*” di dalam jurnal *Eurocrypt’94*

Visual Cryptography*

Moni Naor †

Adi Shamir ‡

Abstract

In this paper we consider a new type of cryptographic scheme, which can decode concealed images without any cryptographic computations. The scheme is perfectly secure and very easy to implement. We extend it into a visual variant of the k out of n secret sharing problem, in which a dealer provides a transparency to each one of the n users; any k of them can see the image by stacking their transparencies, but any $k - 1$ of them gain no information about it.

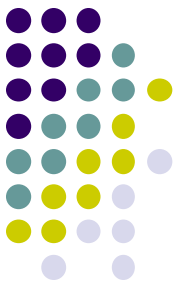

- Enkripsi dilakukan dengan membagi gambar menjadi sejumlah bagian yang disebut ***share***.
- Setiap *share* terlihat seperti citra acak yang tak bermakna sehingga disebut juga *shadow*.

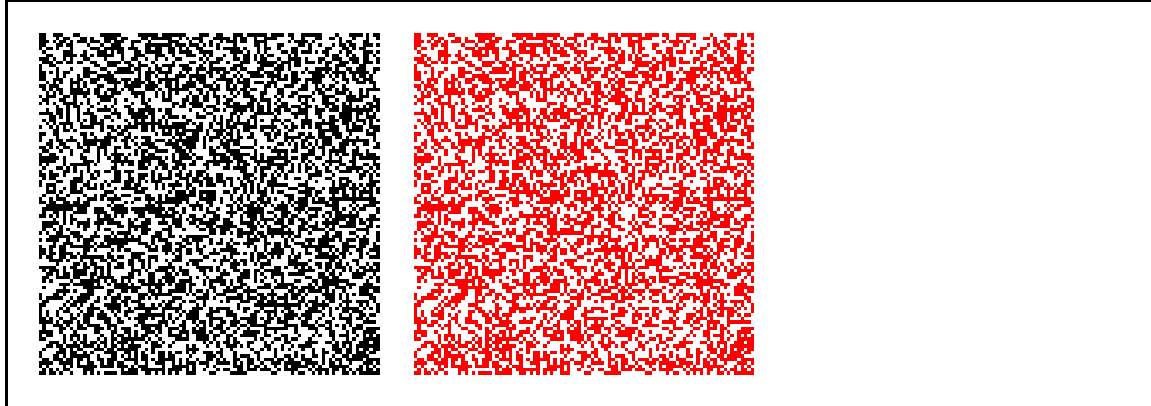

- Tidak membutuhkan komputasi untuk dekripsi citra. Dekripsi dilakukan dengan menumpuk sejumlah *share*.

Contoh:

Plainteks

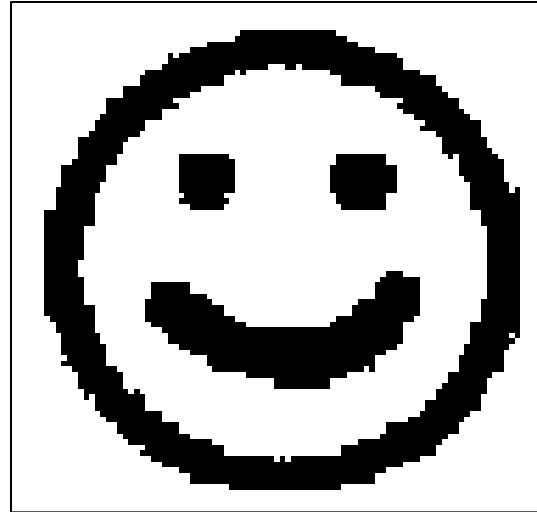

enkripsi

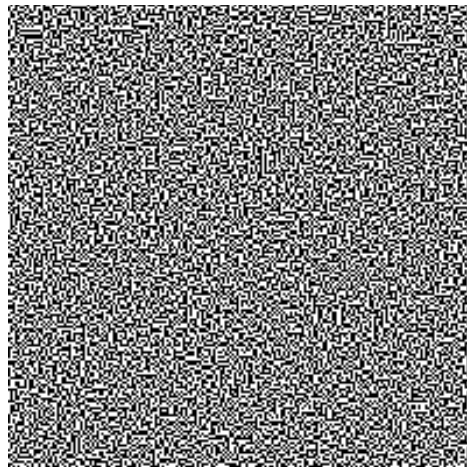

Share 1

dekripsi

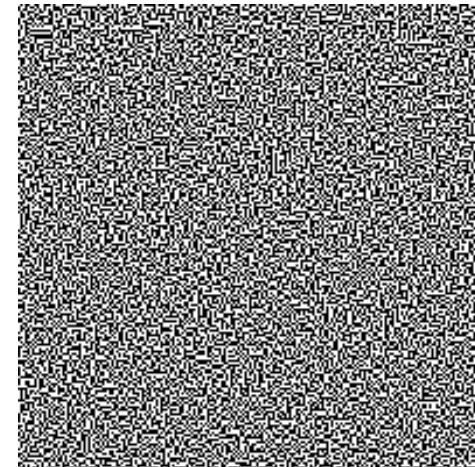

Share 2

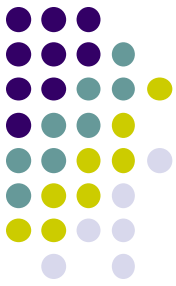

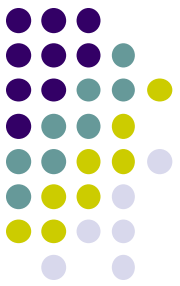

Hasil dekripsi:

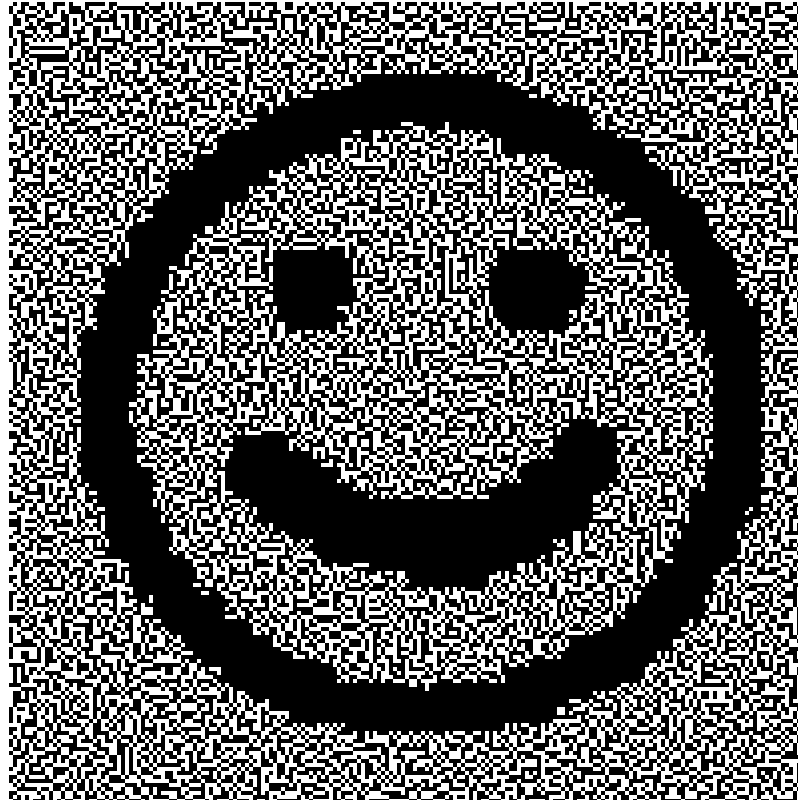

Contoh lain:



Plain-image

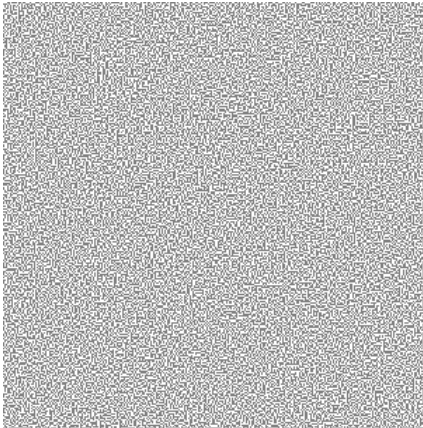

Share 1

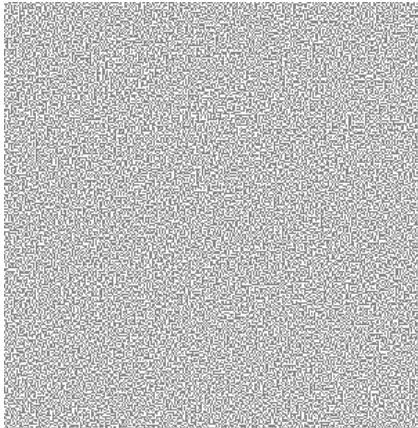

Share 2

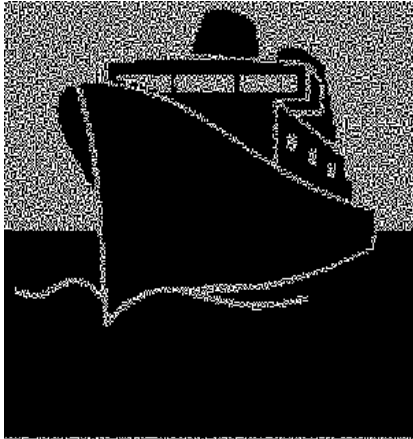

Share 1 + Share 2

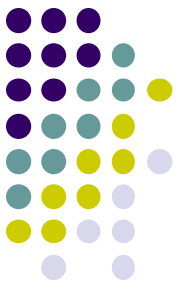

- Untuk keamanan, maka dalam kriptografi visual, pembagian gambar menjadi sejumlah *share* dilakukan oleh pihak ketiga yang terpercaya, yang disebut ***dealer***.
- Sedangkan pihak yang menerima *share* dinamakan ***partisipant***.
- Dekripsi dilakukan oleh *partisipant* dengan menumpuk *share* yang mereka miliki (misalnya setiap *share* dicetak pada plastik transparan)



- Skenario penggunaan

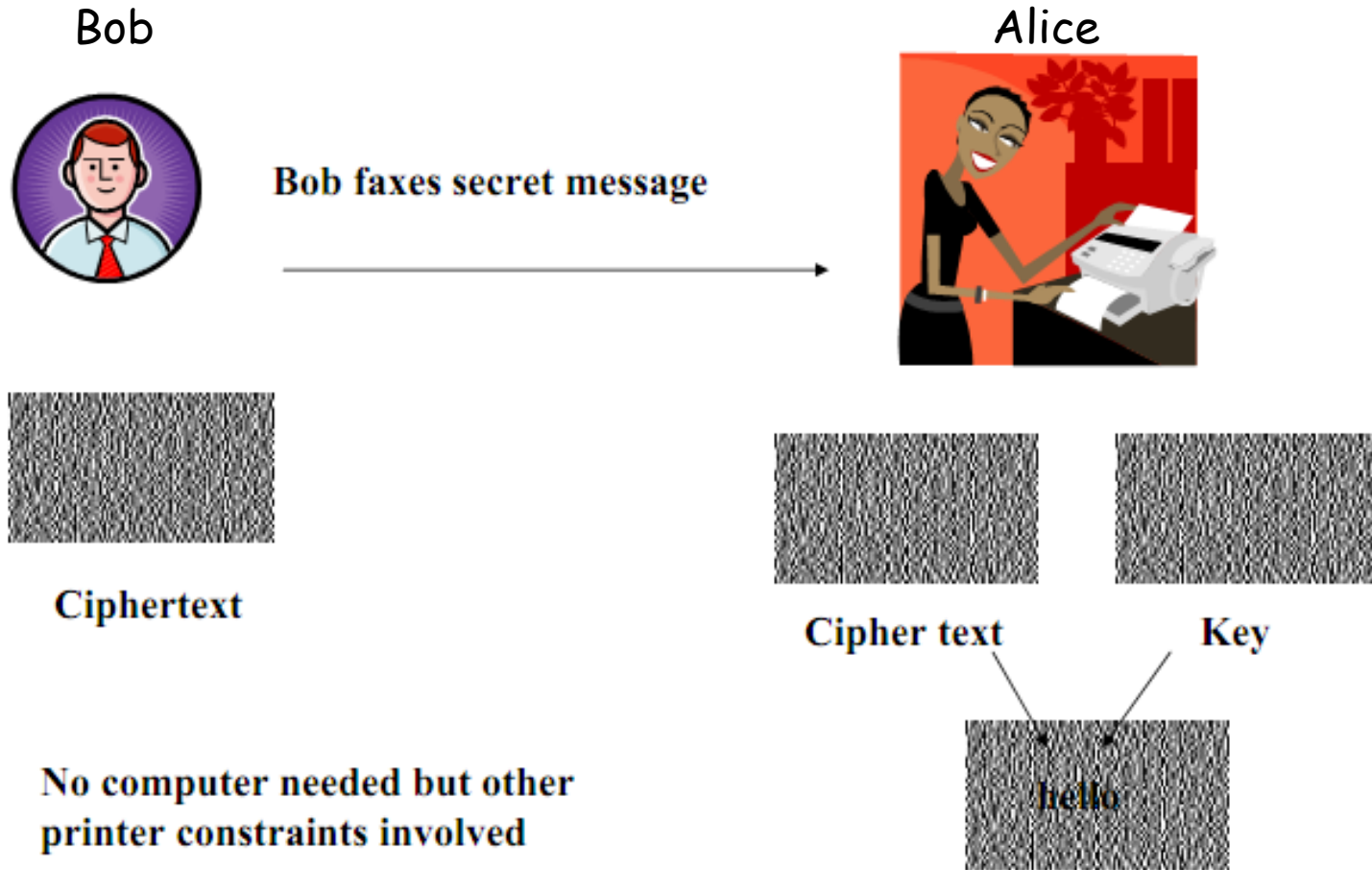

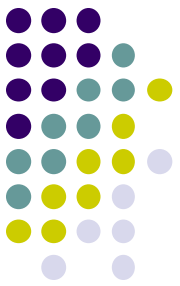

Kriptografi *versus* Kriptografi Visual

- Kriptografi
 - Kriptografi tradisional
 - Simetri: DES, AES, RC4, Blowfish, dll
 - Nir-simetri: RSA, ElGamal, ECC, dll
 - Proses enkripsi dan dekripsi membutuhkan komputasi yang tinggi
 - Memerlukan kunci untuk enkripsi dan dekripsi
- Kriptografi Visual
 - Komputasi rendah
 - Dekripsi dilakukan tanpa komputasi, *fast decoding*
 - Tidak membutuhkan kunci untuk enkripsi dan dekripsi
 - *Share* itu sendiri sudah berlaku sebagai kunci

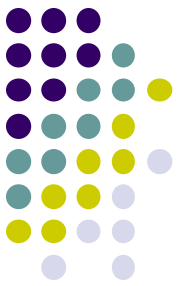

- Kriptografi Tradisionil

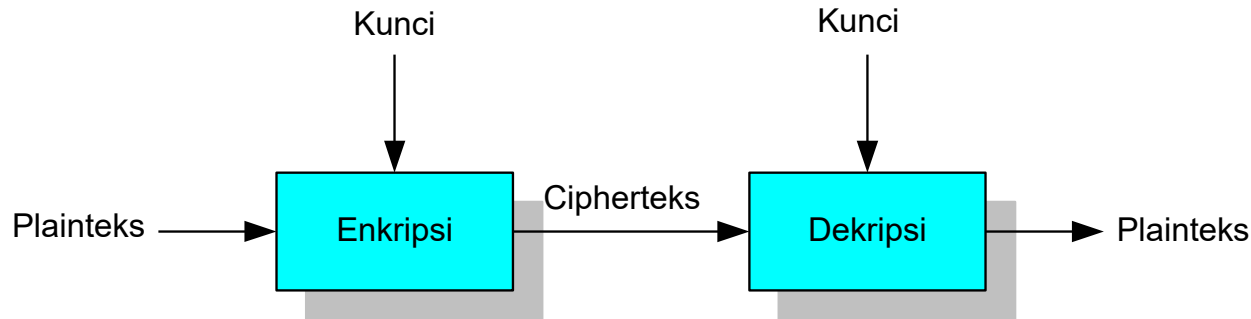

Ketika saya berjalan-jalan di pantai, saya menemukan banyak sekali kepiting yang merangkak menuju laut. Mereka adalah anak-anak kepiting yang baru menetas dari dalam pasir. Naluri mereka mengatakan bahwa laut adalah tempat kehidupan mereka.

(a) Plainteks (teks)

Ztāxzp/épép/qtüyp{p}<yp{p}/sx/□p}
âpx;pêp/|t}t|āzp}/qp}êpz/étzp{x/z
t□xâx}v□□ép}v/|tüp}vzp/|t}âyä/(p
ää=/\tützp□□psp{pw/p}pz<p}pz/zt□x
âx}v/ép}v/qpüä□□|t)tâpé/spüx/sp{p
|/□péxü=/]p{äüx□□|ttüzp/|t}vpâpzp
}/qpwâp/{pää/psp{pw□□ât|□pâ/ztwxs
ä□p}/|tützp=

(b) Cipherteks dari (a)

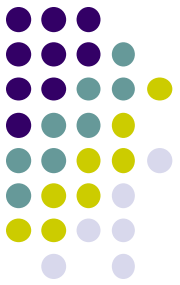

● Kriptografi Visual

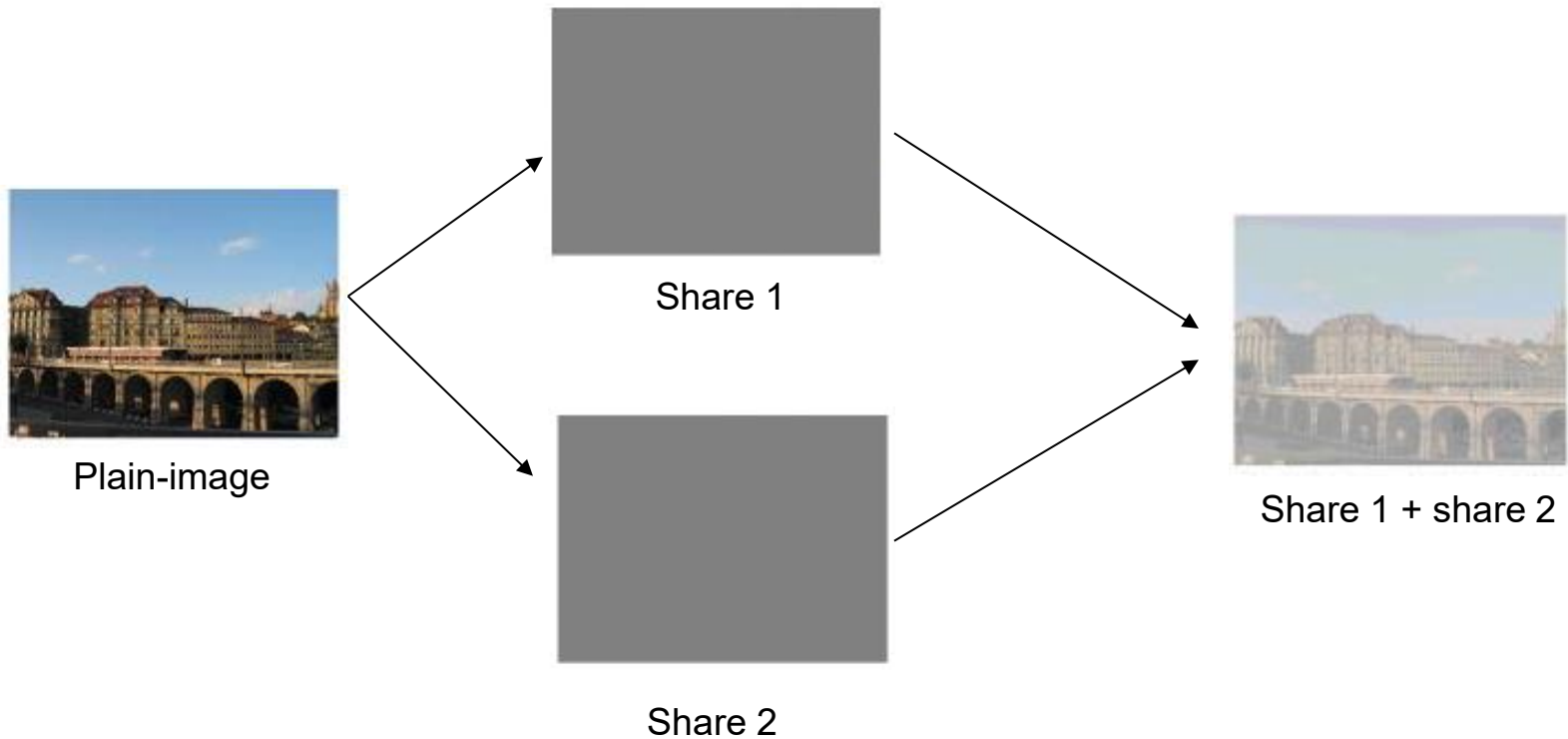
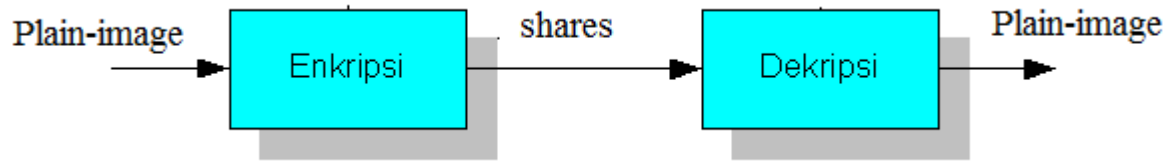

Konsep Citra Digital

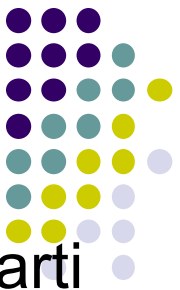

- Citra terdiri dari sejumlah *pixel*. Citra 1200 x 1500 berarti memiliki 1200 x 1500 pixel = 1.800.000 pixel

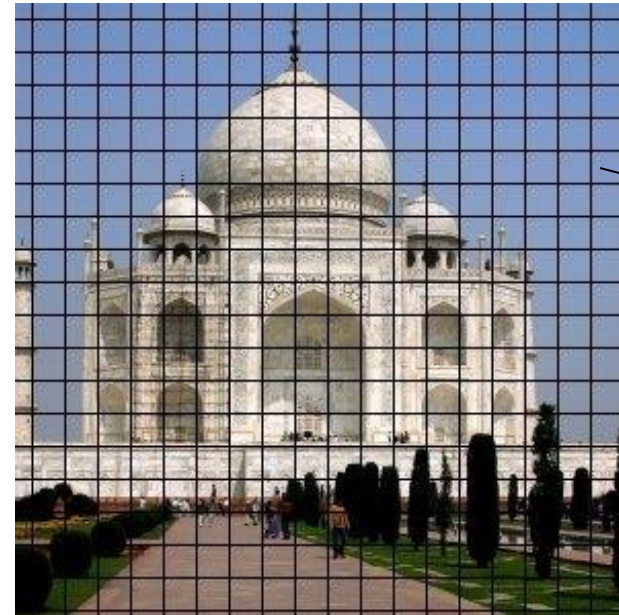

- Setiap *pixel* panjangnya n -bit.
Citra biner \rightarrow 1 bit/pixel
Citra *grayscale* \rightarrow 8 bit/pixel
Citra *true color* \rightarrow 24 bit/pixel

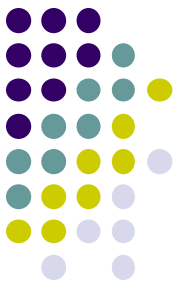

Citra Lenna



True color image
(24-bit)



Grayscale image
(8-bit)



Bimary image
(1-bit)

Citra berwarna terdiri dari komponen *RGB* (*Red-Green-Blue*)

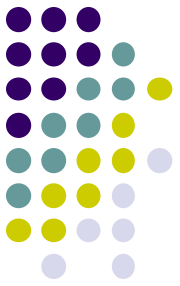

Original Image



Red



Green



Blue

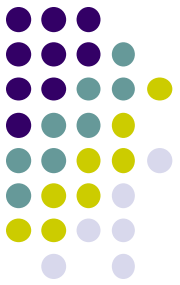

Pada citra berwarna 24-bit (*real image*),
1 pixel = 24 bit,

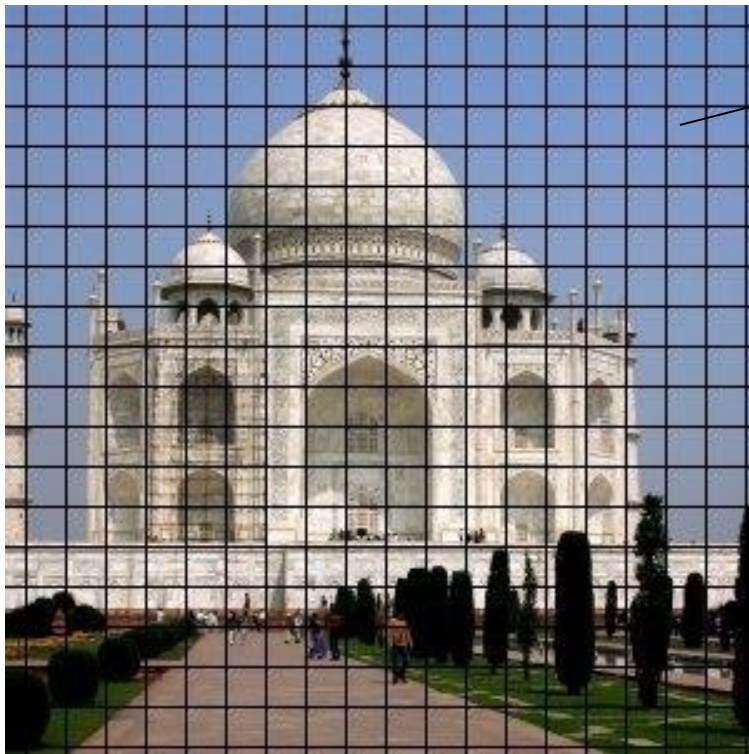

→ 100100111001010010001010
R G B

Kriptografi Visual pada Citra Biner





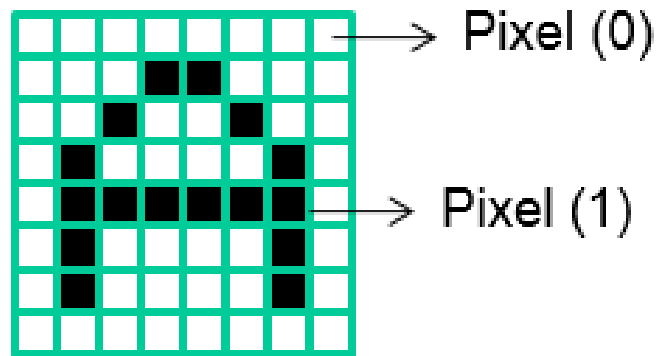



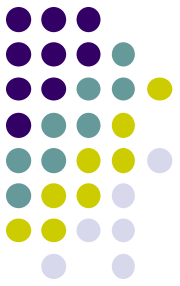







- Tinjau kriptografi visual untuk citra biner
- *Pixel* pada citra biner:
 - bernilai 1 jika hitam
 - bernilai 0 jika putih



$$\begin{bmatrix} 0 & 0 & 0 & 0 & 0 & 0 & 0 & 0 & 0 \\ 0 & 0 & 0 & 1 & 1 & 0 & 0 & 0 & 0 \\ 0 & 0 & 1 & 0 & 0 & 1 & 0 & 0 & 0 \\ 0 & 1 & 0 & 0 & 0 & 0 & 1 & 0 & 0 \\ 0 & 1 & 1 & 1 & 1 & 1 & 1 & 1 & 0 \\ 0 & 1 & 0 & 0 & 0 & 0 & 1 & 0 & 0 \\ 0 & 1 & 0 & 0 & 0 & 0 & 1 & 0 & 0 \\ 0 & 0 & 0 & 0 & 0 & 0 & 0 & 0 & 0 \end{bmatrix}$$

Bagaimana cara kerja kriptografi visual?

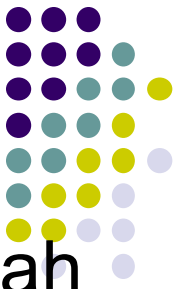

- Setiap *pixel* dibagi menjadi sejumlah *sub-pixel*.
- Setiap *pixel* muncul pada setiap *share*
- Jika *sub-pixel* dari setiap *share* ditumpuk, hasilnya *pixel* yang dipersepsi sebagai “putih” atau “hitam”.

Pixel	Share #1	+	Share #2	=	Hasil
		+		=	
		+		=	
		+		=	
		+		=	



- Skema lainnya, satu *pixel* dibagi menjadi 4 buah *sub-pixel*

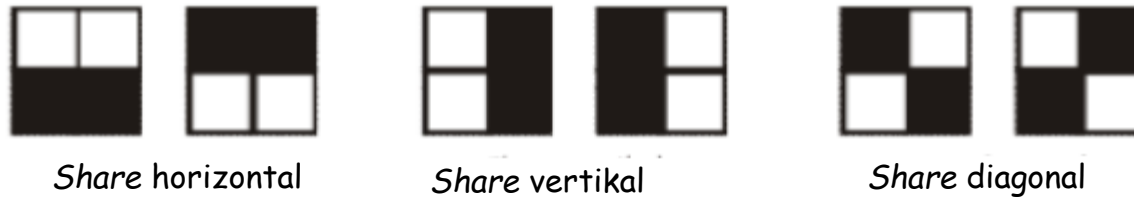

- Penumpukan:

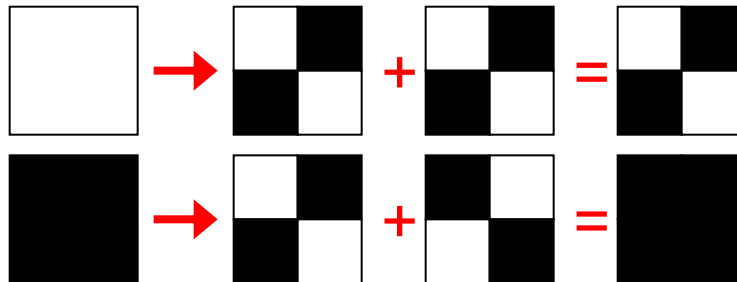

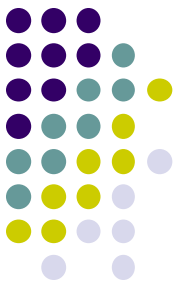

- Setiap *share* dicetak pada plastik transparansi.
- Jika dua buah *share* ditumpuk, maka mata manusia mempersepsi *pixel* yang terbentuk sebagai “hitam” atau “putih”
- Apa warna yang dipersepsi dari penumpukan di bawah ini?

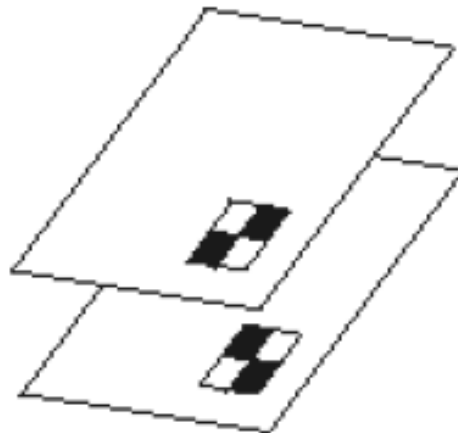

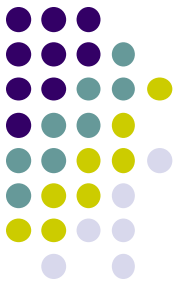

- Penumpukan dua atau lebih *share* dapat dipandang sebagai operasi “OR”

$$\begin{pmatrix} 0 & 0 \\ 1 & 1 \end{pmatrix} \text{ or } \begin{pmatrix} 1 & 1 \\ 0 & 0 \end{pmatrix} = \begin{pmatrix} 1 & 1 \\ 1 & 1 \end{pmatrix}$$



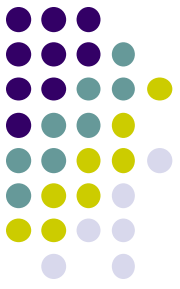

- Dalam implementasinya, membagi 1 *pixel* menjadi 2 *sub-pixel* dilakukan dengan meng-*extend* 1 *pixel* menjadi 2 *pixel*.
- Akibatnya, ukuran *share* menjadi dua kali ukuran gambar semula

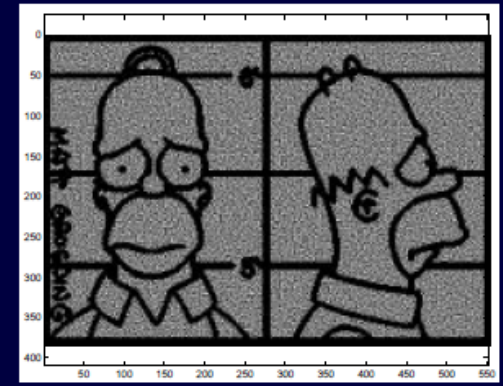
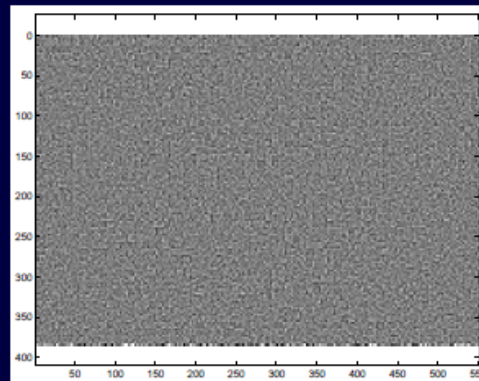
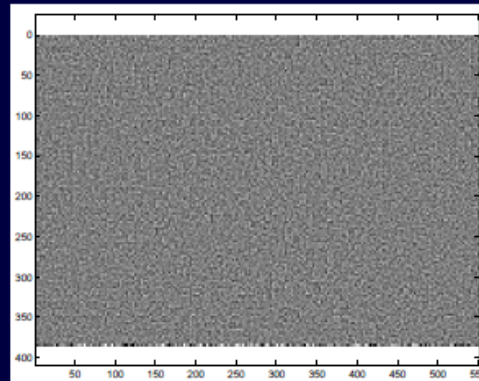
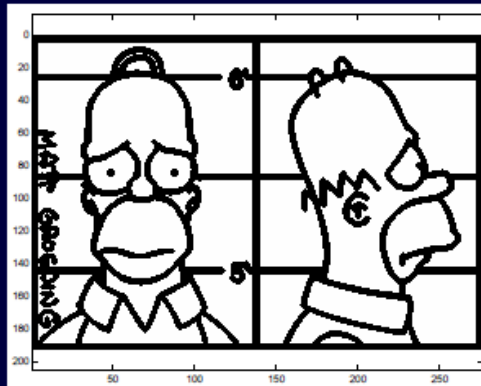

Contoh:

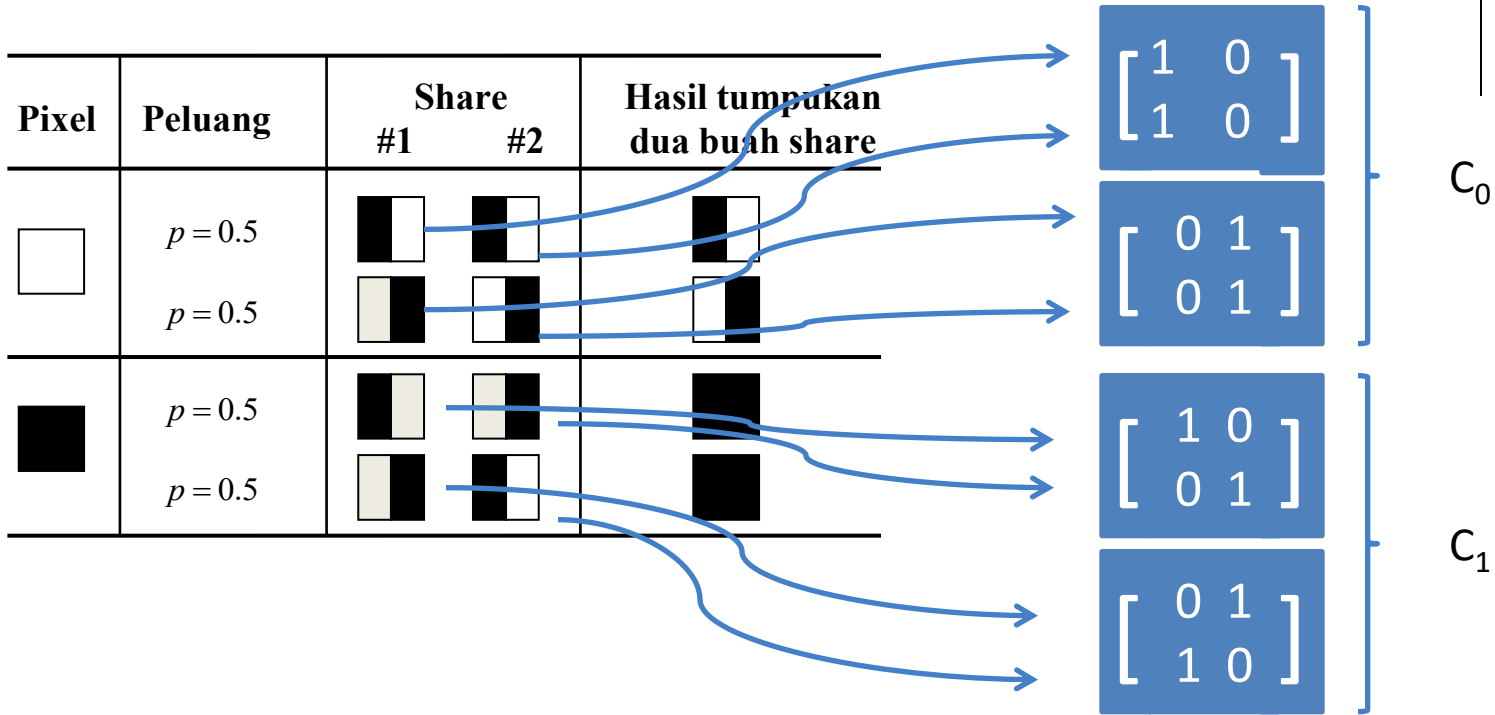

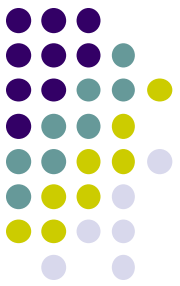

Skema (2, 2)

- Satu gambar dibagi menjadi dua buah *share*
- Untuk mendekripsi, diperlukan dua buah *share*
- Algoritma enkripsi (membagi gambar menjadi dua *share*):
 1. Ambil sebuah *pixel* dari gambar (*plain-image*), misal *pixel P*
 2. Jika *P* berwarna putih, ambil secara acak sebuah matriks *S* pada C_0
Jika *P* berwarna hitam, ambil secara acak sebuah matriks *S* pada C_1
Misalkan *P* berwarna hitam dan matriks yang diambil dari C_1 adalah sebagai berikut:
$$S = \begin{bmatrix} 1 & 0 \\ 0 & 1 \end{bmatrix}$$
maka *share* 1 adalah baris 1 dari *S* dan *share* 2 adalah baris 2 dari *S*



Share 1

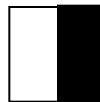

Share 2

4. Ulangi langkah 2 dan 3 untuk *pixel-pixel* lainnya

Contoh:

pixel



Alternatif 1

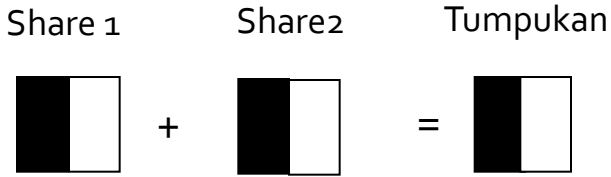

Alternatif 2



$$C_0 = \left\{ \begin{bmatrix} 1 & 0 \\ 1 & 0 \end{bmatrix}, \begin{bmatrix} 0 & 1 \\ 0 & 1 \end{bmatrix} \right\}$$

Share 1

Share 2

Tumpukan

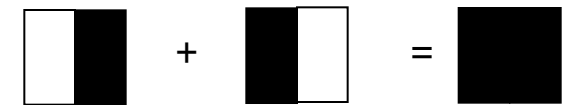
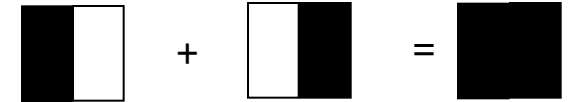

$$C_1 = \left\{ \begin{bmatrix} 1 & 0 \\ 0 & 1 \end{bmatrix}, \begin{bmatrix} 0 & 1 \\ 1 & 0 \end{bmatrix} \right\}$$

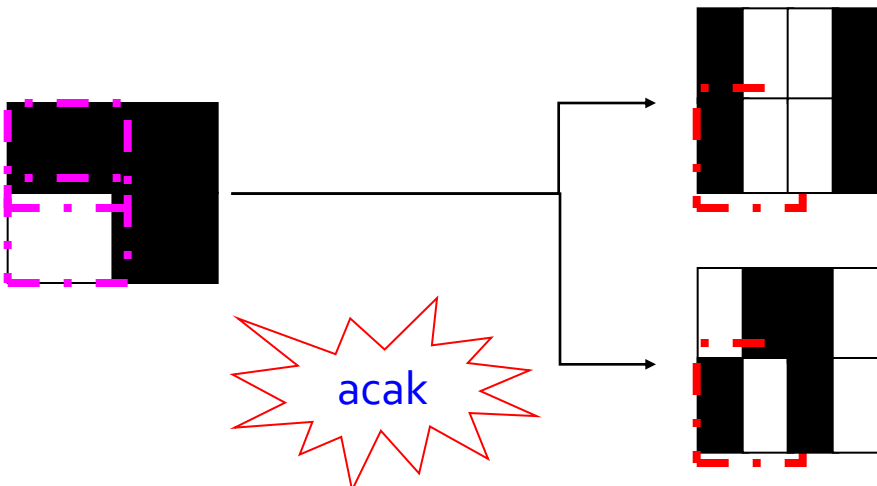

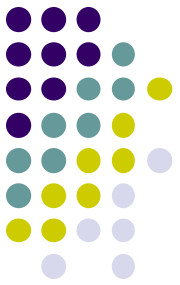

● Contoh skema (2, 2) lainnya:

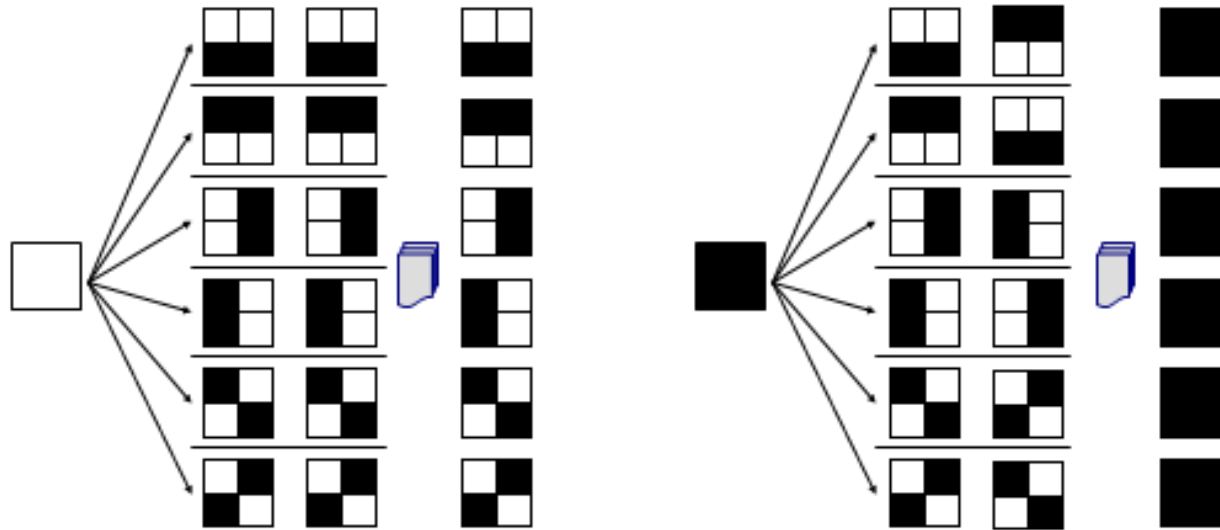
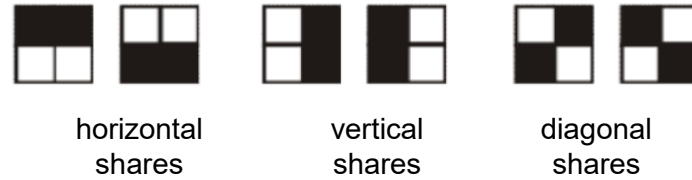

$$C_0 = \left\{ \begin{bmatrix} 0 & 0 & 1 & 1 \\ 0 & 0 & 1 & 1 \end{bmatrix}, \begin{bmatrix} 1 & 1 & 0 & 0 \\ 1 & 1 & 0 & 0 \end{bmatrix}, \begin{bmatrix} 1 & 0 & 1 & 0 \\ 1 & 0 & 1 & 0 \end{bmatrix}, \begin{bmatrix} 0 & 1 & 0 & 1 \\ 0 & 1 & 0 & 1 \end{bmatrix}, \begin{bmatrix} 1 & 0 & 0 & 1 \\ 1 & 0 & 0 & 1 \end{bmatrix}, \begin{bmatrix} 0 & 1 & 1 & 0 \\ 0 & 1 & 1 & 0 \end{bmatrix} \right\}$$

$$C_1 = \left\{ \begin{bmatrix} 0 & 0 & 1 & 1 \\ 1 & 1 & 0 & 0 \end{bmatrix}, \begin{bmatrix} 1 & 1 & 0 & 0 \\ 0 & 0 & 1 & 1 \end{bmatrix}, \begin{bmatrix} 1 & 0 & 1 & 0 \\ 0 & 1 & 0 & 1 \end{bmatrix}, \begin{bmatrix} 0 & 1 & 0 & 1 \\ 1 & 0 & 1 & 0 \end{bmatrix}, \begin{bmatrix} 1 & 0 & 0 & 1 \\ 0 & 1 & 1 & 0 \end{bmatrix}, \begin{bmatrix} 0 & 1 & 1 & 0 \\ 1 & 0 & 0 & 1 \end{bmatrix} \right\}$$



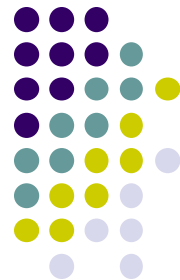

horizontal shares



vertical shares



diagonal shares

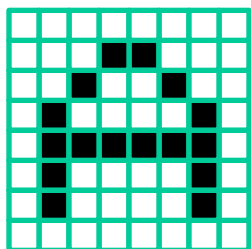

Secret Image

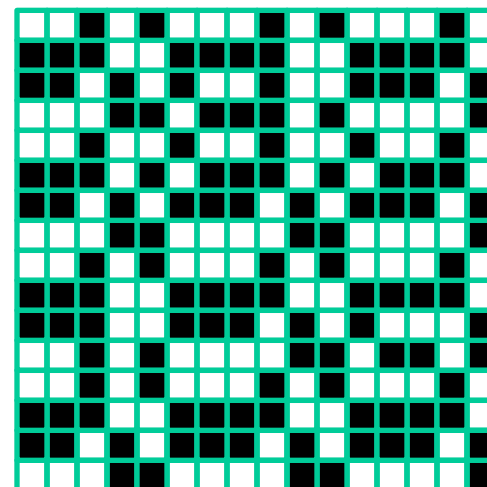
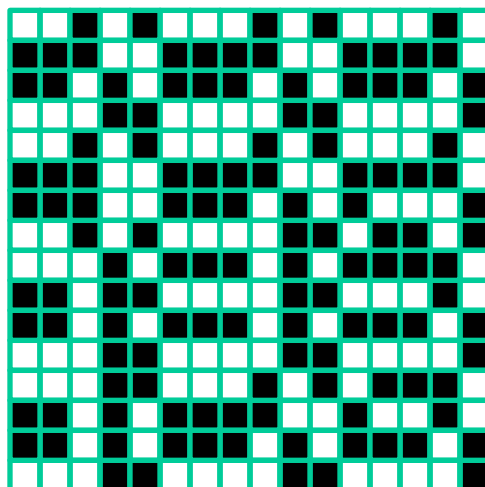

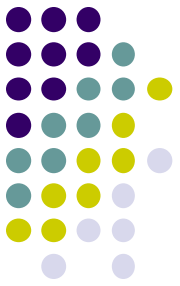

horizontal shares



vertical shares

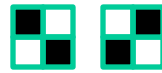

diagonal shares

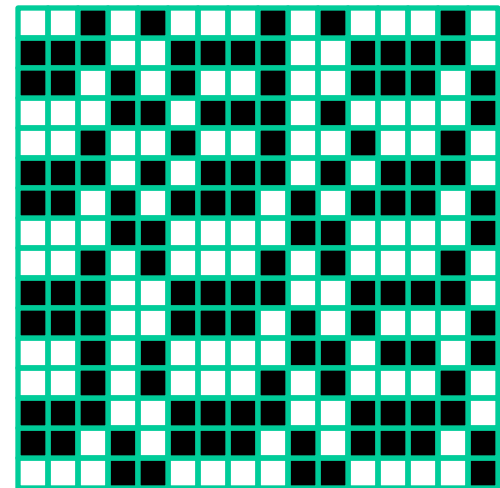
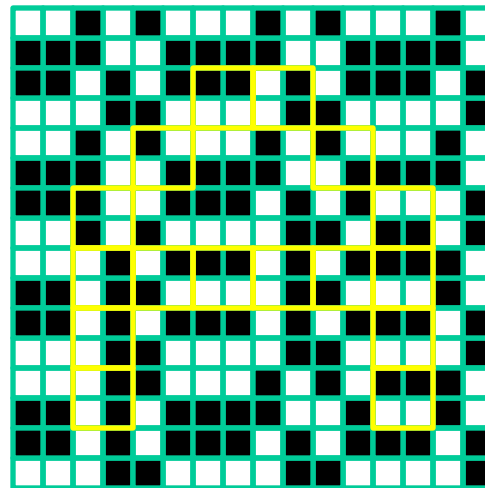
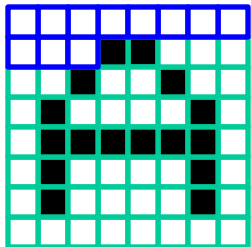



Contoh lainnya:

Secret pixel color \ Share blocks	White						Black					
2x2 block of the first share												
2x2 block of the second share												
Stacked 2x2 block												

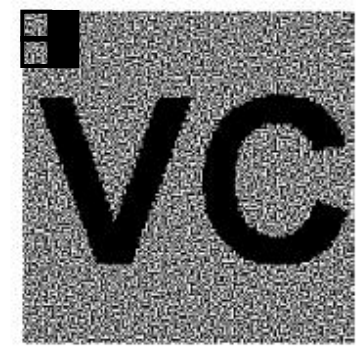
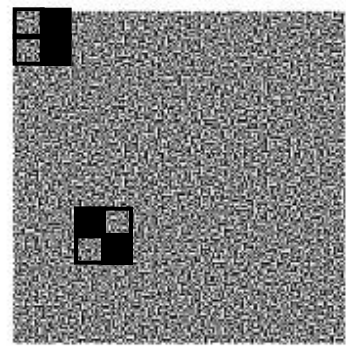
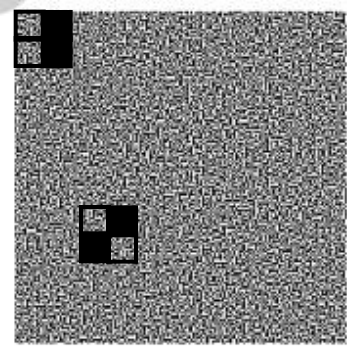

(a) Original secret image

(b) First share image

(c) Second share image

(d) Stacked result of (a) and (b)

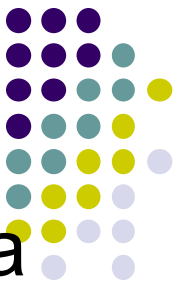

- Contoh-contoh kriptografi visual sederhana

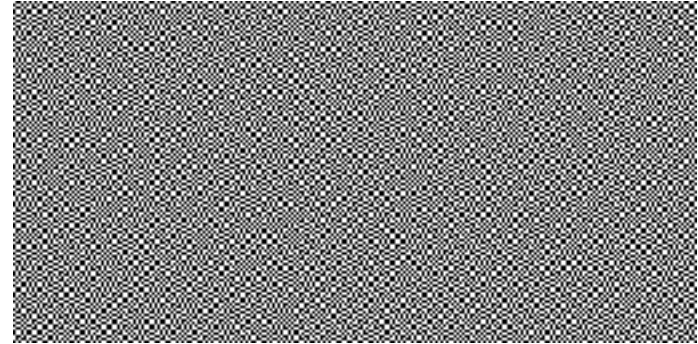
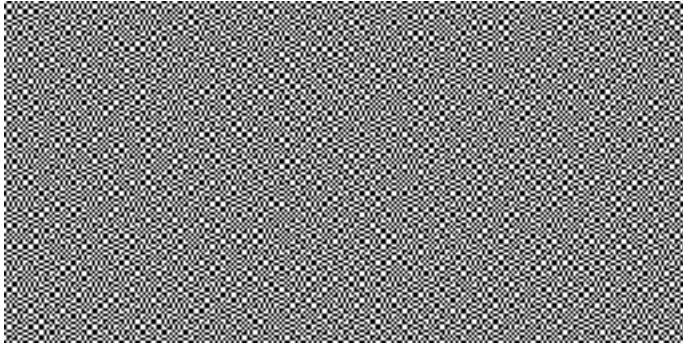



**Mathematics is made of
50 percent formulas,
50 percent proofs, and**

Anyone knows what is the secret?

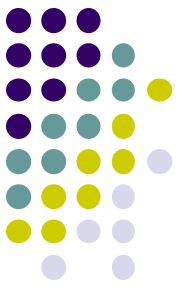

Original

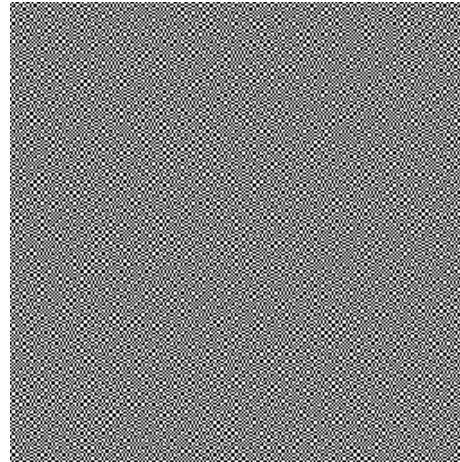

Share 1

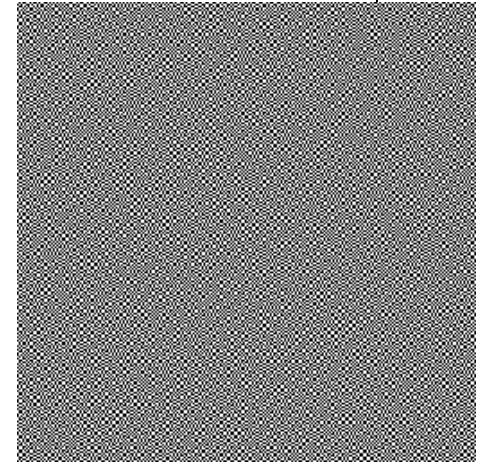

Share 2



**Hasil penumpukan *share 1*
dan *share 2***

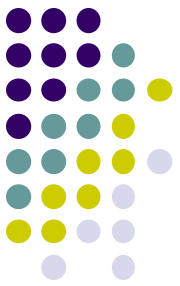

Referensi

1. Arif Ramdhoni, *Kriptografi Visual pada Citra Biner dan Berwarna serta Pengembangannya dengan Steganografi dan Fungsi XOR*, Tugas Akhir Informatika ITB, 2008.
2. Rinaldi Munir, *Bahan Kuliah IF4020 Kriptografi*, Program Studi Informatika STEI-ITB, 2014.
3. Semin Kim, *Visual Cryptography, Advanced Information Security*, Korea Advanced Institute of Science and Technology (KAIST), 2010.
4. Chin-Chen Chang, *Visual Cryptography*, National Tsing Hua University, Taiwan.
5. Kristin Burke, *Visual Cryptography*
6. Hossein Hajiabolhassan, *Visual Cryptography*, Department of of Mathematical Sciences Shahid Beheshti University, Tehran, Iran, 2009
7. Zhi Zhou, Gonzalo R. Arce, and Giovanni Di Crescenzo, *Halftone Visual Cryptography*, IEEE TRANSACTIONS ON IMAGE PROCESSING, VOL. 15, NO. 8, AUGUST 2006, pp. 2441-2453

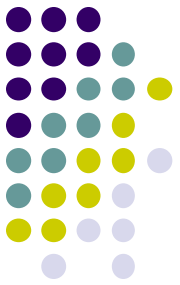

8. Salik Jamal and Warsi, Siddharth Bora, *Visual Cryptography*.
9. Jiangyi Hu, *Visual Cryptography*
10. Frederik Vercauteren, *Visual Cryptography*, University of Bristol, 2001
11. Ricardo Martin, *Visual Cryptography: Secret Sharing without a Computer*, GWU Cryptography Group, 2005

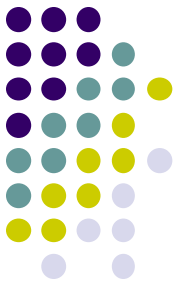

BERSAMBUNG