

12 – Penapisan Citra dalam Ranah Frekuensi

IF4073 Interpretasi dan Pengolahan Citra

Oleh: Rinaldi Munir



Program Studi Teknik Informatika
Sekolah Teknik Elektro dan Informatika
Institut Teknologi Bandung
2023

Penapisan dalam ranah frekuensi

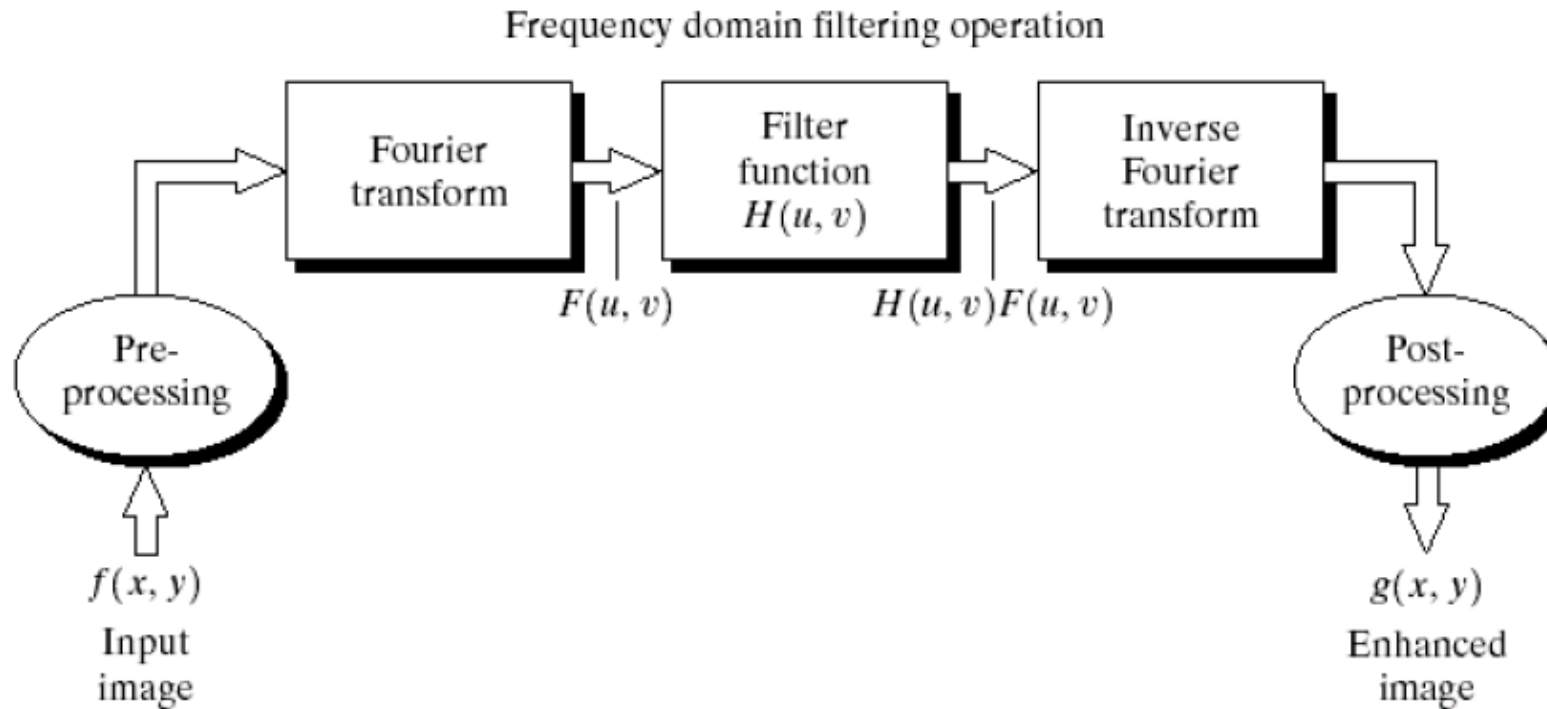

FIGURE 4.5 Basic steps for filtering in the frequency domain.

Hubungan antara operasi penapisan dalam ranah spasial dan ranah frekuensi:

$$g(x,y) = h(x,y)*f(x,y) \leftrightarrow G(u,v) = H(u,v)F(u,v)$$

dan sebaliknya: $g(x,y) = h(x,y)f(x,y) \leftrightarrow G(u,v) = H(u,v) * F(u,v)$

Catatan: ukuran matriks $H(u,v)$ dan $F(u,v)$ harus sama

```
>> A = magic(5)
```

```
A =
```

```
17 24 1 8 15
23 5 7 14 16
4 6 13 20 22
10 12 19 21 3
11 18 25 2 9
```

```
>> C = fft2(A).*fft2(B)
```

```
C =
```

```
8125 0 0 0 0
0 0 0 0 0
0 0 0 0 0
0 0 0 0 0
0 0 0 0 0
```

```
>> B = ones(5)
```

```
B =
```

```
1 1 1 1 1
1 1 1 1 1
1 1 1 1 1
1 1 1 1 1
1 1 1 1 1
```

```
>> D = ifft2(C)
```

```
D =
```

```
325 325 325 325 325
325 325 325 325 325
325 325 325 325 325
325 325 325 325 325
325 325 325 325 325
```

- Perhatikan bahwa penapisan dalam ranah spasial dan dalam ranah frekuensi keduanya berkoresponden.

$$f(x,y) * h(x,y) \Leftrightarrow H(u,v) F(u,v)$$

- Contoh: citra *pepper* akan dilakukan *sharpening* pada ranah spasial dan ranah frekuensi. Penapis yang digunakan adalah

$$\begin{bmatrix} 0 & -1 & 0 \\ -1 & 5 & -1 \\ 0 & -1 & 0 \end{bmatrix}$$

$\Sigma = 1$

- Penapisan dalam ranah spasial:

```
f=imread('lada-gray.bmp');  
imshow(f), title('Original image');  
h = [0 -1 0; -1 5 -1; 0 -1 0];  
fsharp = uint8(convn(double(f), double(h)));  
figure, imshow(fsharp), title('Sharp image');
```

Original image



Sharp image



- Penapisan dalam ranah frekuensi:

```
[f, map] = imread('lada-gray.bmp');  
imshow(f, map), title('Original image');  
h = [0 -1 0; -1 5 -1; 0 -1 0];  
[M,N] = size(f);  
F = fft2(double(f));  
H = fft2(double(h),M,N);  
F2 = H.*F;  
f2 = ifft2(F2);  
g=real(f2);  
figure, imshow(g, map), title('Sharp image');
```

Original image



Sharp image

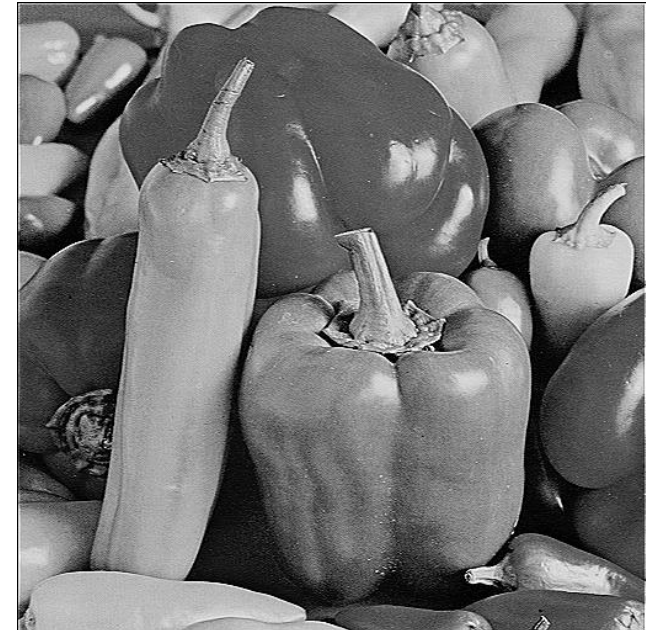

Lowpass filter (LPF) dalam ranah frekuensi

- Penapis lolos rendah (*lowpass filter*) bertujuan menekan komponen berfrekuensi tinggi dan membiarkan komponen berfrekuensi rendah relatif tidak berubah.
- Menghasilkan efek *blurring* (atau *smoothed image*)
- Tiga buah LPF yang utama:
 1. *Ideal lowpass filter* (ILPF)
 2. *Gaussian lowpass filter* (GLPF)
 3. *Butterworth lowpass filter* (BLPF)

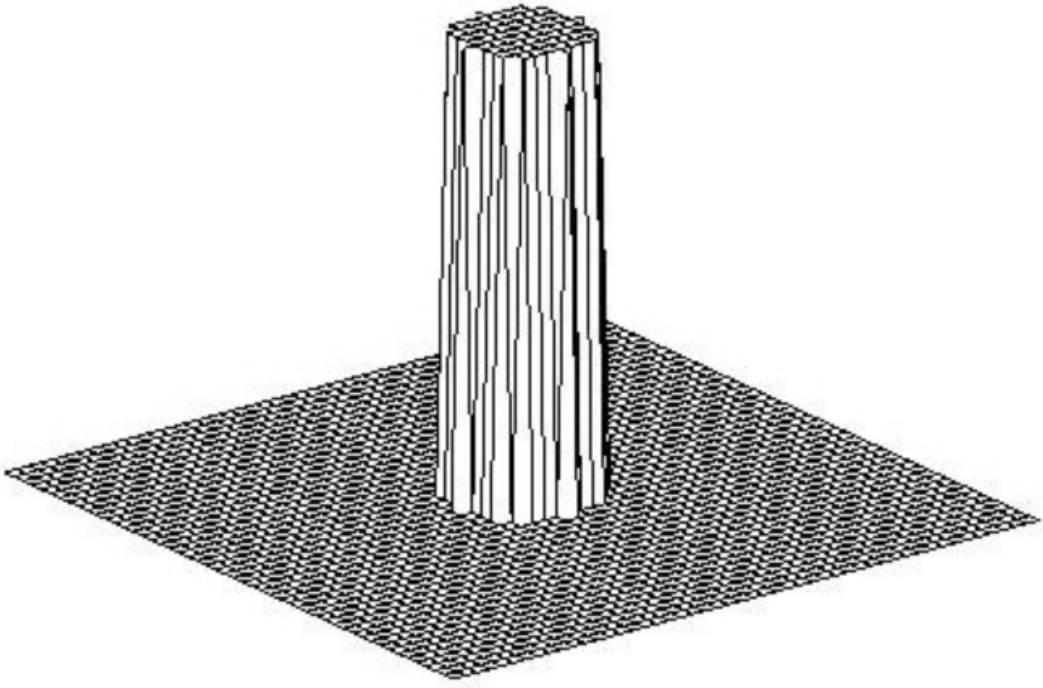
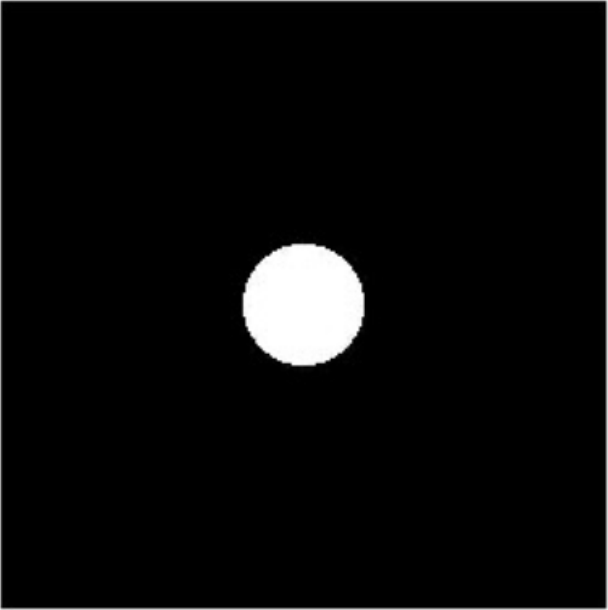
Lowpass Filter	Formula	Mesh	Image
Ideal	$H(u, v) = \begin{cases} 1 & \text{if } D(u, v) \leq D_0 \\ 0 & \text{if } D(u, v) > D_0 \end{cases}$		



Where $D(u, v)$ is the distance from point (u, v) to the center of the frequency rectangle

If the center is at $(M/2, N/2)$

$$D(u, v) = \sqrt{(u - M/2)^2 + (v - N/2)^2}$$

• D_0 : cutoff frequency

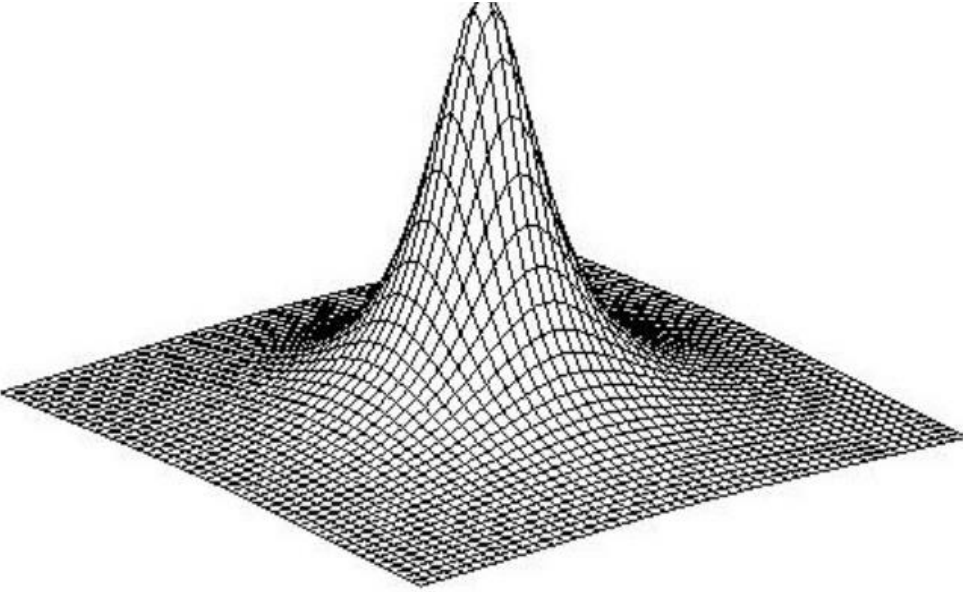
Sumber: <https://www.cs.uregina.ca/Links/class-info/425-nova/Lab5/index.html>

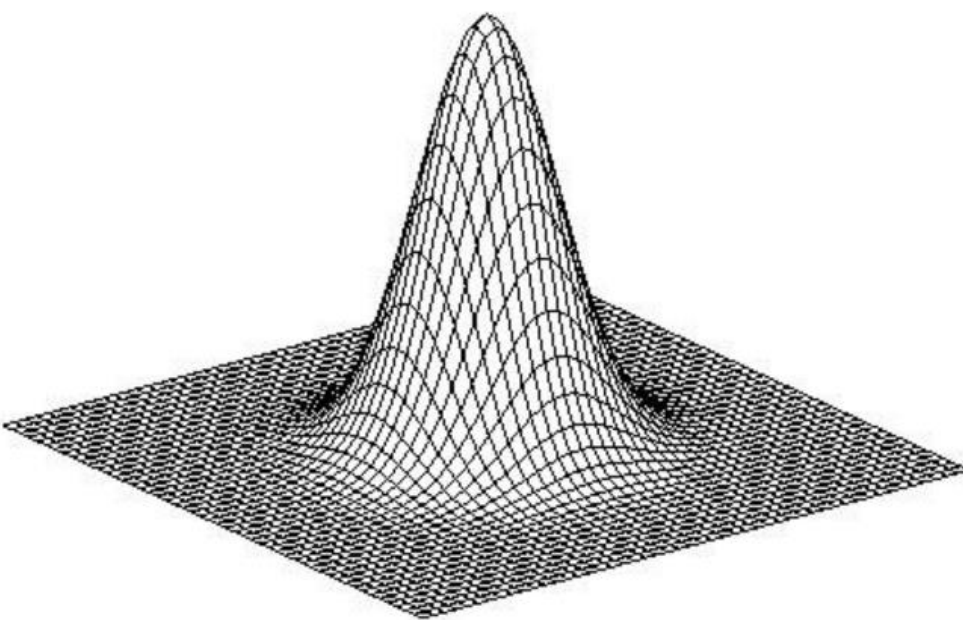
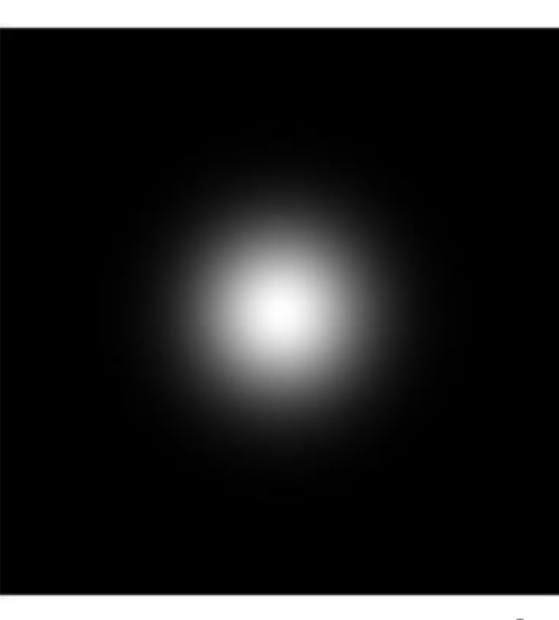
Butterworth	$H(u, v) = \frac{1}{1 + [D(u, v) / D_0]^{2n}}$		
Gaussian	$H(u, v) = e^{-D^2(u, v) / 2D_0^2}$		

Ideal Low Pass Filter (ILPF)

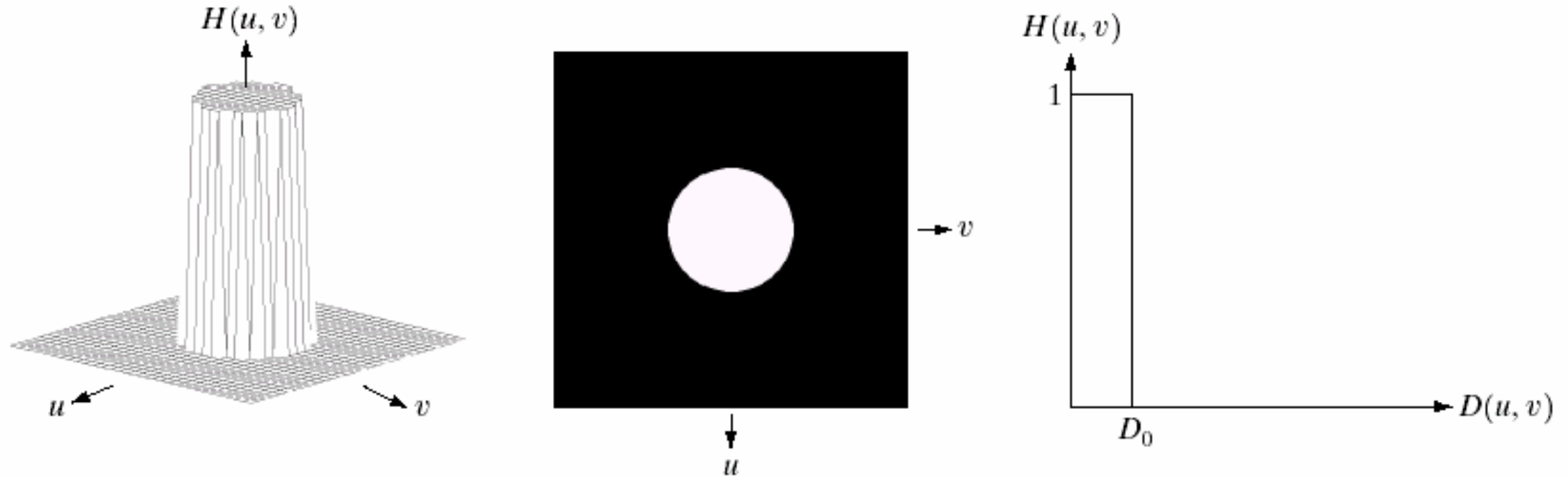

a b c

FIGURE 4.10 (a) Perspective plot of an ideal lowpass filter transfer function. (b) Filter displayed as an image. (c) Filter radial cross section.

Gaussian Low Pass Filter (GLPF)

$$H(u, v) = e^{-D^2(u, v)/2D_0^2}$$

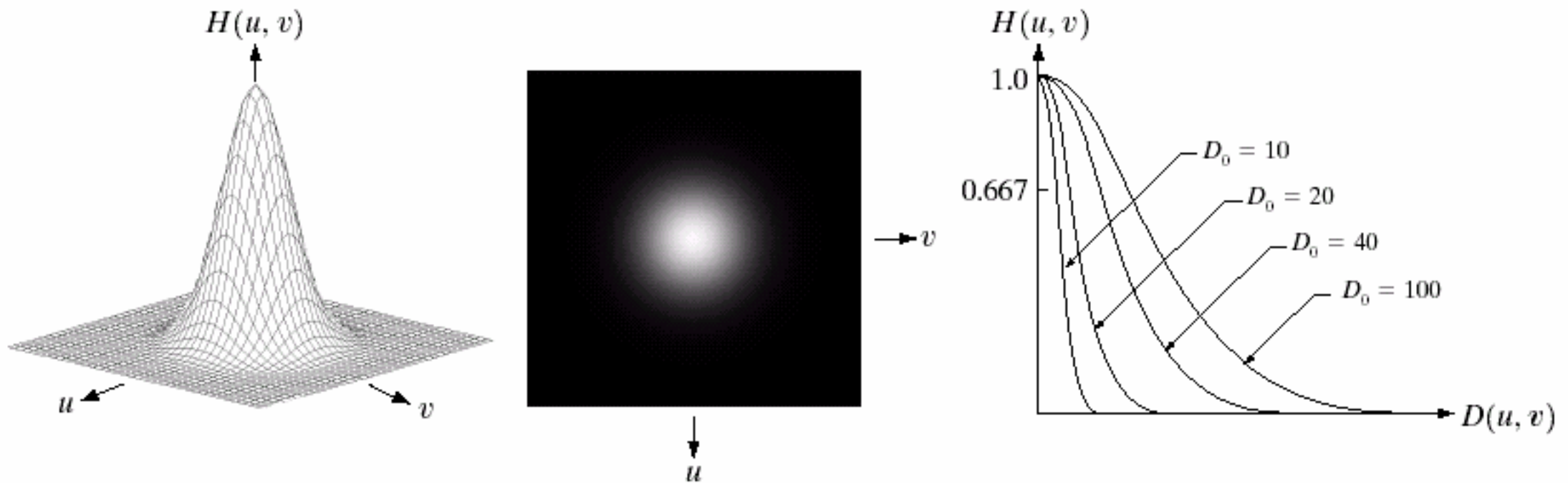

a b c

FIGURE 4.17 (a) Perspective plot of a GLPF transfer function. (b) Filter displayed as an image. (c) Filter radial cross sections for various values of D_0 .

Butterworth Pass Filter (BLPF)

$$H(u, v) = \frac{1}{1 + [D(u, v) / D_0]^{2n}}$$

n : filter order

D_0 : cutoff frequency

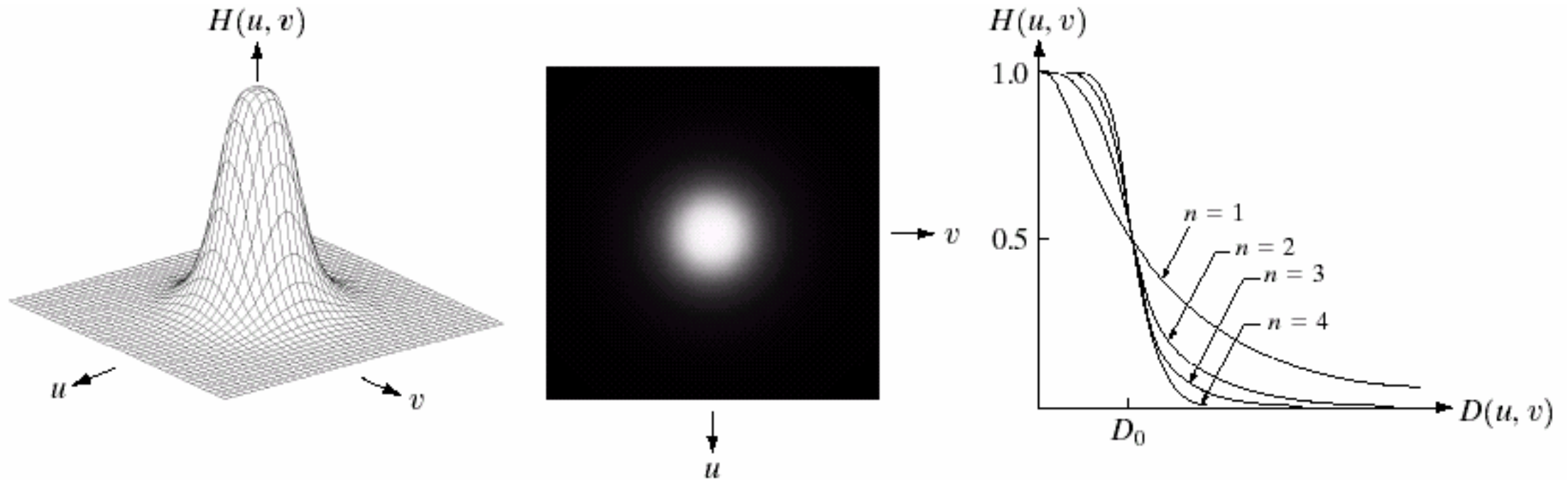

a b c

FIGURE 4.14 (a) Perspective plot of a Butterworth lowpass filter transfer function. (b) Filter displayed as an image. (c) Filter radial cross sections of orders 1 through 4.

Langkah-Langkah penapisan dalam ranah frekuensi (dengan Matlab):

1. Tentukan parameter *padding*, biasanya untuk citra $f(x,y)$ berukuran $M \times N$, umumnya parameter *padding* P dan Q adalah $P = 2M$ and $Q = 2N$.
2. Bentuklah citra *padding* $f_p(x,y)$ berukuran $P \times Q$ dengan menambahkan pixel-pixel bernilai nol pada $f(x, y)$.
3. Lakukan transformasi Fourier pada $f_p(x, y)$
Kode Matlab: $F = \text{fft2}(f_p);$
Catatan: Langkah 2 dan 3 dapat digabung menjadi sbb: $F = \text{fft2}(f, P, Q);$
4. Bangkitkan fungsi penapis H berukuran $P \times Q$
Catatan: jika penapis diambil dari matriks pada ranah spasial, transformasi penapis dengan Fourier transform.
5. Kalikan F dengan H
Kode Matlab: $G = H .* F;$
6. Ambil bagian real dari inverse FFT of G :
Kode Matlab: $g = \text{real}(\text{ifft2}(G));$
7. Potong bagian kiri atas sehingga menjadi berukuran citra semula
 $g = g(1:\text{size}(f,1), 1:\text{size}(f,2));$

Catatan:

Langkah *padding* (1 dan 2) adalah opsional, bertujuan agar citra $f(x,y)$ dan penapis $H(u,v)$ memiliki ukuran yang sama

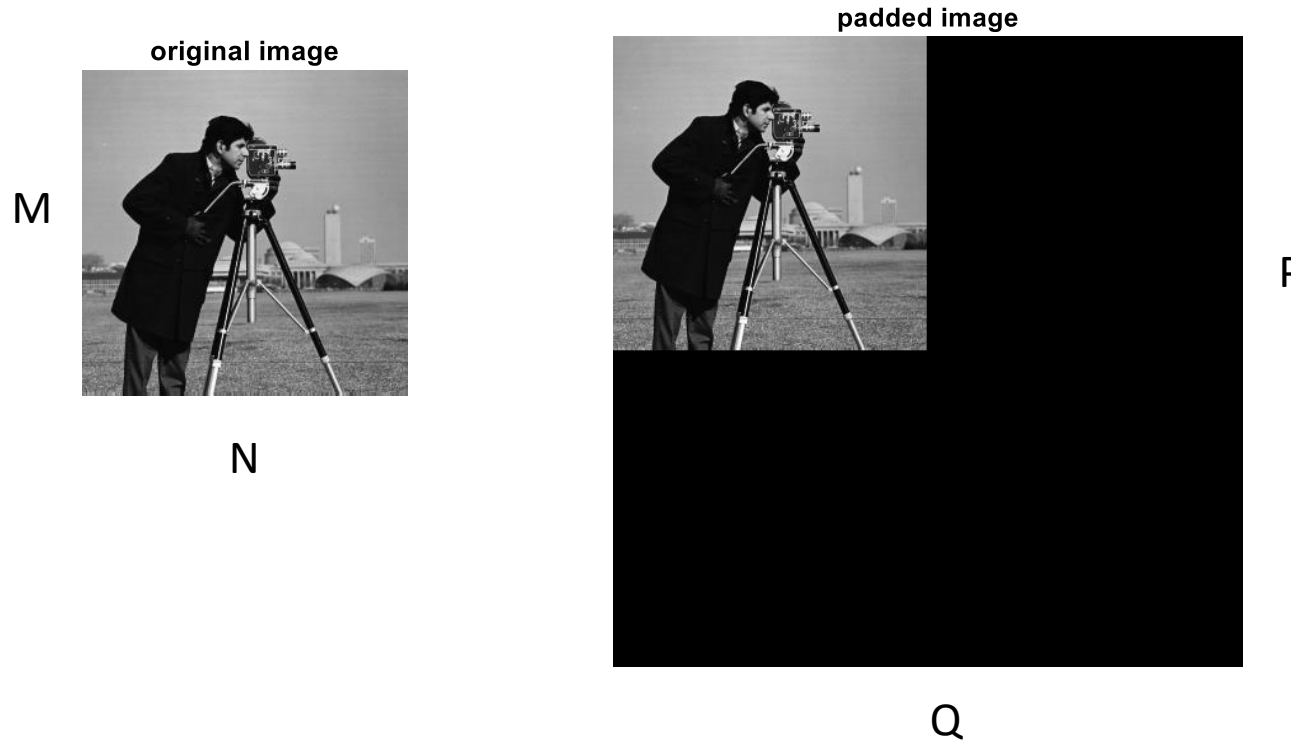

```

% Penapisan dalam ranah frekuensi dengan Ideal Lowpass Filter (ILPF)
f=imread('camera.bmp');
imshow(f);
[M,N] = size(f);
%Step 1: Tentukan parameter padding, biasanya untuk citra f(x,y)
%          berukuran M x N, parameter padding P dan Q adalah P = 2M and Q = 2N.
P = 2*M;
Q = 2*N;

%Step 2: Bentuklah citra padding fp(x,y) berukuran P X Q dengan
%          menambahkan pixel-pixel bernilai nol pada f(x, y).
f = im2double(f);
for i = 1:P
    for j = 1:Q
        if i <= M && j<= N
            fp(i,j) = f(i,j);
        else
            fp(i,j) = 0;
        end
    end
end
end
imshow(f);title('original image');
figure; imshow(fp);title('padded image');

```

```

% Display the Fourier Spectrum
Fc=fftshift(fft2(fp)); % move the origin of the transform to the center of
the frequency rectangle
S2=log(1+abs(Fc)); % use abs to compute the magnitude (handling imaginary)
and use log to brighten display
figure, imshow(S2,[]); title('Fourier spectrum');

%Step 3: Lakukan transformasi Fourier pada fpad(x, y)
F = fft2(double(fp));

%Step 4: Bangkitkan fungsi penapis H berukuran P x Q, misalkan penapis
%yang digunakan adalah Ideal Lowpass Filter (ILPF)

D0 = 50; % cut-off frequency
% Set up range of variables.
u = 0:(P-1);
v = 0:(Q-1);

% Compute the indices for use in meshgrid
idx = find(u > P/2);
u(idx) = u(idx) - P;
idy = find(v > Q/2);
v(idy) = v(idy) - Q;

```



```

% Compute the meshgrid arrays
[V, U] = meshgrid(v, u);
D = sqrt(U.^2 + V.^2);

H = double(D <=D0);
H = fftshift(H); figure;imshow(H);title('LPF Ideal Mask');
figure, mesh(H);

%Step 5: Kalikan F dengan H
H = ifftshift(H);
LPF_f = H.*F;

%Step 6: Ambil bagian real dari inverse FFT of G:
LPF_f2=real(ifft2(LPF_f)); % apply the inverse, discrete Fourier transform
figure; imshow(LPF_f2);title('output image after inverse 2D DFT');

%Step 7: Potong bagian kiri atas sehingga menjadi berukuran citra semula
LPF_f2=LPF_f2(1:M, 1:N); % Resize the image to undo padding
figure, imshow(LPF_f2); title('output image');

```

Sumber: Program di atas merupakan modifikasi dari program yang diambil dari sini:

1. <https://www.cs.uregina.ca/Links/class-info/425-nova/Lab5/index.html>
2. <https://www.mathworks.com/matlabcentral/fileexchange/53250-filtering-of-an-image-in-frequency-domain>

original image



padded image



Fourier spectrum

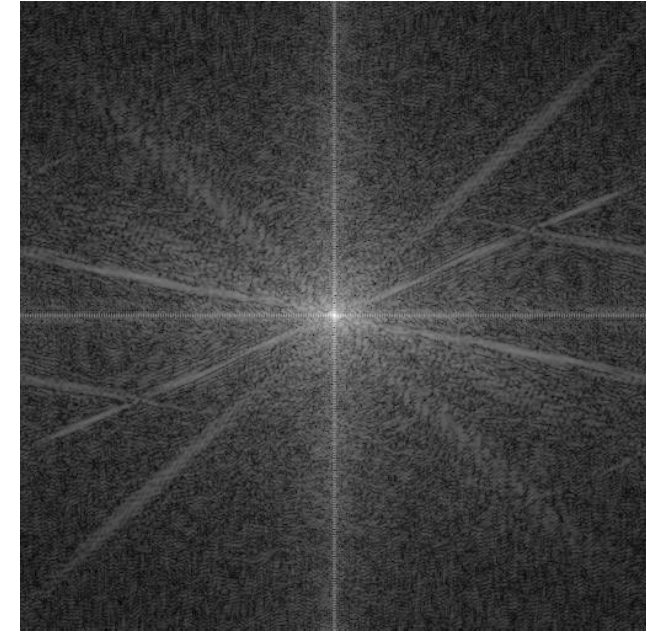

LPF Ideal Mask

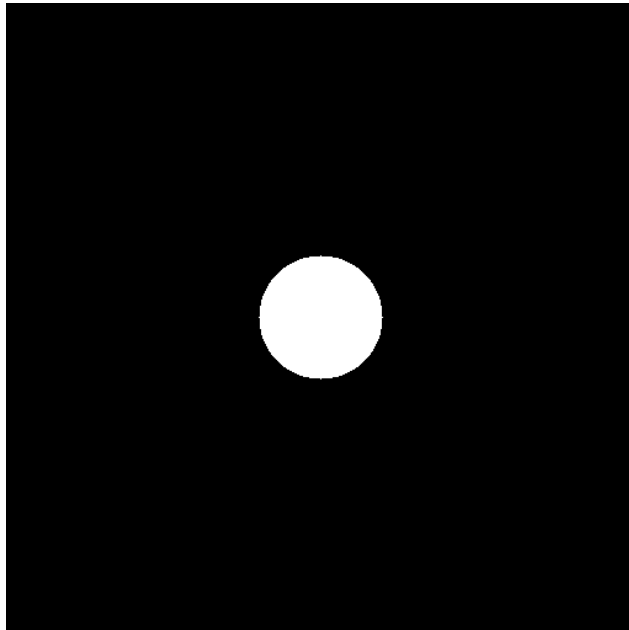

output image after inverse 2D DFT



output image



Hasil run program
dengan ILPF, $D_0 = 50$

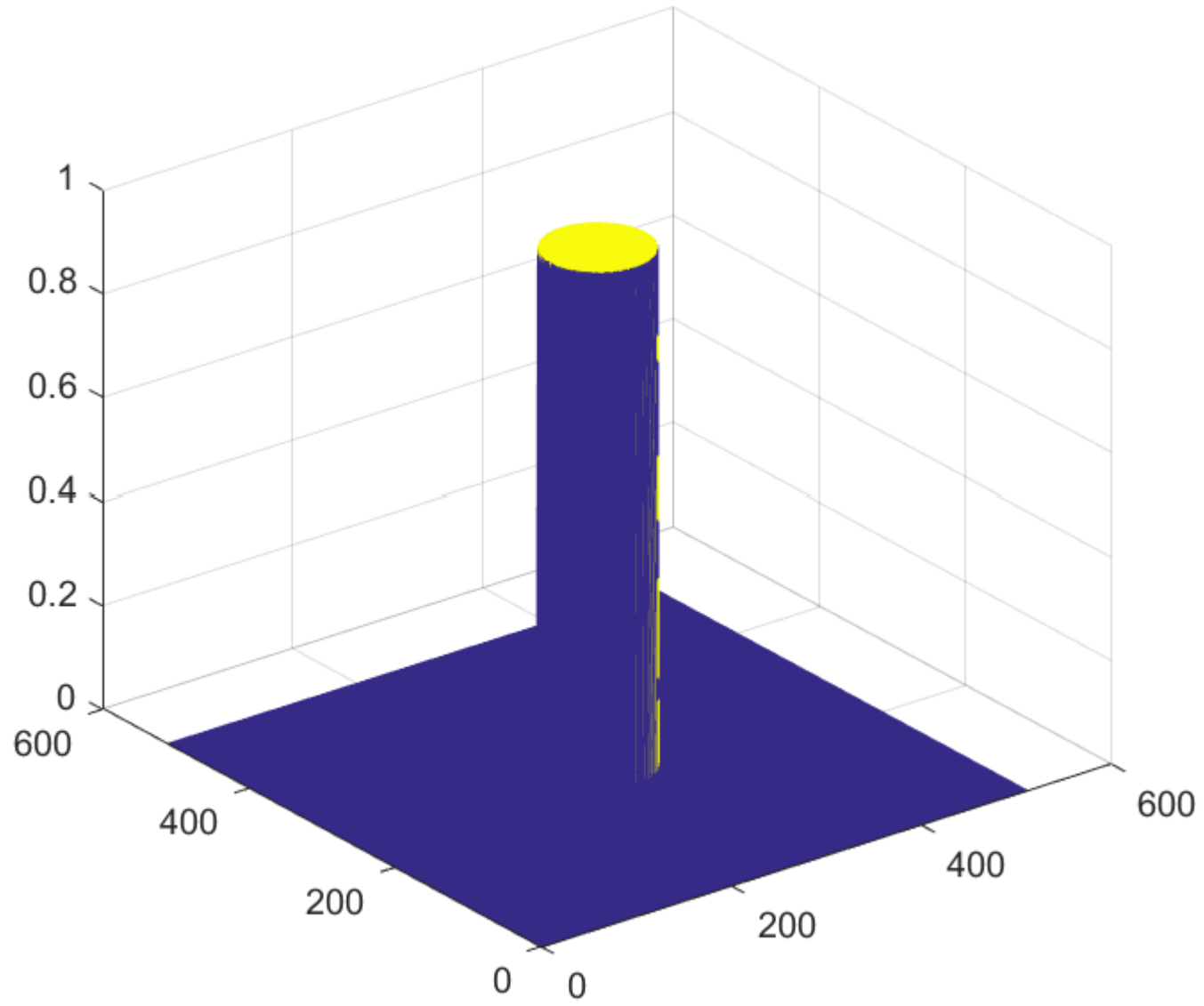

mesh(H)

Catatan: *Padding* tidak selalu harus dilakukan, program di atas tetap benar jika tidak dilakukan *padding*, yaitu $P = M$, dan $Q = N$.

Semula:

```
% Penapisan dalam ranah frekuensi
% dengan Ideal Lowpass Filter (ILPF)
f=imread('camera.bmp');
imshow(f);
[M,N] = size(f);
% Step 1: Tentukan parameter padding,
% biasanya untuk citra f(x,y)
% berukuran M x N, parameter padding P dan Q
% adalah  $P = 2M$  and  $Q = 2N$ .
P = 2*M;
Q = 2*N;
```

Menjadi

```
% Penapisan dalam ranah frekuensi
% dengan Ideal Lowpass Filter (ILPF)
f=imread('camera.bmp');
imshow(f);
[M,N] = size(f);
%Step 1: Tentukan parameter padding,
% biasanya untuk citra f(x,y)
% berukuran M x N, parameter padding
% P dan Q adalah  $P = 2M$  and  $Q = 2N$ .
P = M;
Q = N;
```

Hasil run program:

original image



Fourier spectrum

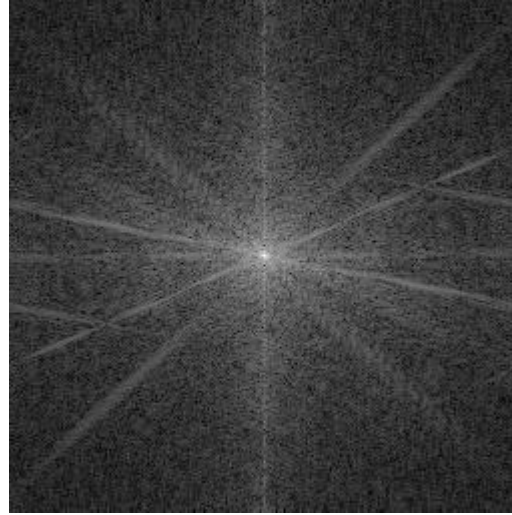

LPF Ideal Mask

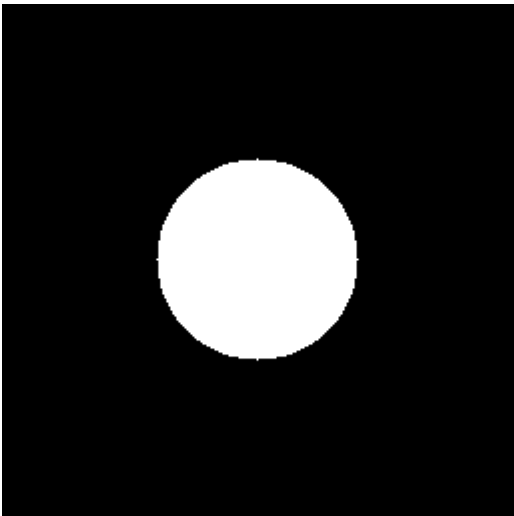

output image

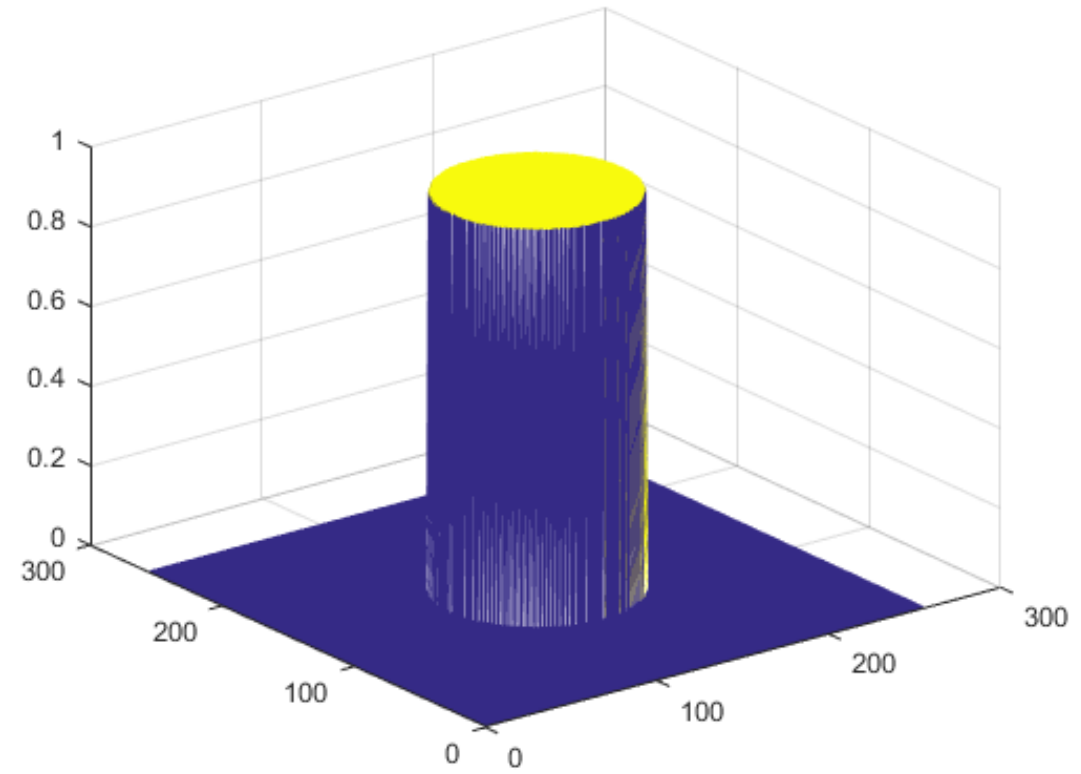

Catatan:

- Untuk GLPF, maka

```
H = double(D <=D0);
```

diganti dengan

```
H = exp(-(D.^2) ./ (2*(D0^2)));
```

- Untuk LPF butterwoth orde n, maka

```
n = 1; % default
```

```
H = 1 ./ (1 + (D./D0).^ (2*n));
```

```

% Penapisan dalam ranah frekuensi dengan Gaussian Lowpass Filter (ILPF)
f=imread('camera.bmp');
imshow(f);
[M,N] = size(f);
%Step 1: Tentukan parameter padding, biasanya untuk citra f(x,y)
%         berukuran M x N, parameter padding P dan Q adalah P = 2M and Q = 2N.
P = 2*M;
Q = 2*N;

%Step 2: Bentuklah citra padding fp(x,y) berukuran P X Q dengan
%         menambahkan pixel-pixel bernilai nol pada f(x, y).
f = im2double(f);
for i = 1:P
    for j = 1:Q
        if i <= M && j<= N
            fp(i,j) = f(i,j);
        else
            fp(i,j) = 0;
        end
    end
end
end
imshow(f);title('original image');
figure; imshow(fp);title('padded image');

```

```

% Display the Fourier Spectrum
Fc=fftshift(fft2(fp)); % move the origin of the transform to the center of
the frequency rectangle
S2=log(1+abs(Fc)); % use abs to compute the magnitude (handling imaginary)
and use log to brighten display
figure, imshow(S2,[]); title('Fourier spectrum');

%Step 3: Lakukan transformasi Fourier pada fpad(x, y)
F = fft2(double(fp));

%Step 4: Bangkitkan fungsi penapis H berukuran P x Q, misalkan penapis
%yang digunakan adalah Ideal Lowpass Filter (ILPF)

D0 = 50; % cut-off frequency
% Set up range of variables.
u = 0:(P-1);
v = 0:(Q-1);

% Compute the indices for use in meshgrid
idx = find(u > P/2);
u(idx) = u(idx) - P;
idy = find(v > Q/2);
v(idy) = v(idy) - Q;

```



```

% Compute the meshgrid arrays
[V, U] = meshgrid(v, u);
D = sqrt(U.^2 + V.^2);

H = exp(-(D.^2) ./ (2*(D0^2)));
H = fftshift(H); figure;imshow(H);title('Gaussian Low Pass Filter');
figure, mesh(H);
%Step 5: Kalikan F dengan H
H = ifftshift(H);
LPF_f = H.*F;

%Step 6: Ambil bagian real dari inverse FFT of G:
LPF_f2=real(ifft2(LPF_f)); % apply the inverse, discrete Fourier transform
figure; imshow(LPF_f2);title('output image after inverse 2D DFT');

%Step 7: Potong bagian kiri atas sehingga menjadi berukuran citra semula
LPF_f2=LPF_f2(1:M, 1:N); % Resize the image to undo padding
figure, imshow(LPF_f2); title('output image');

```

original image



padded image



Fourier spectrum

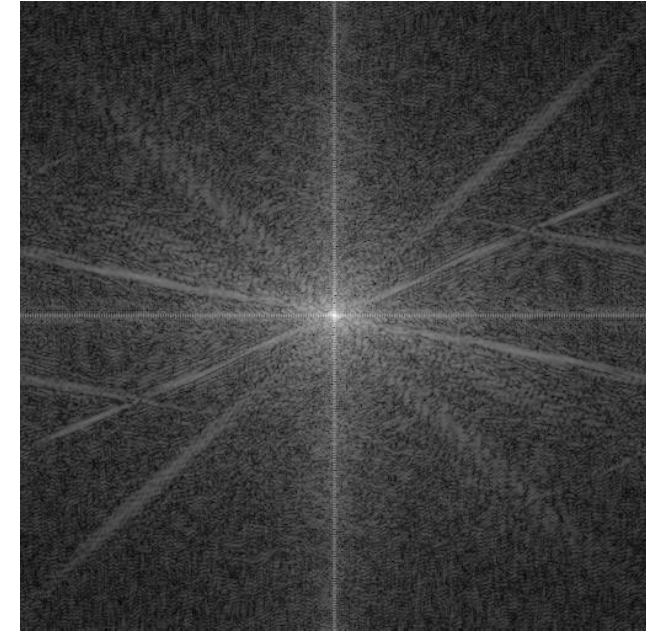

Gaussian Low Pas Filter

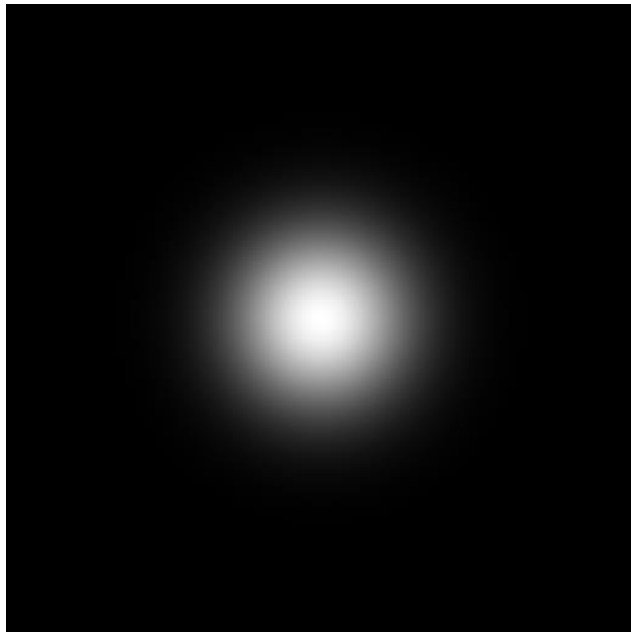

output image after inverse 2D DFT



output image

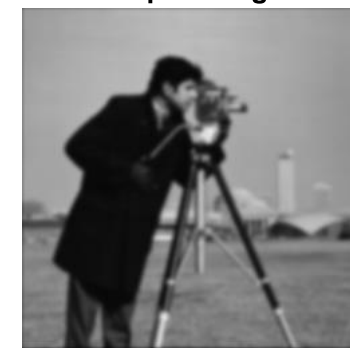

Hasil run program
dengan GLPF, $D0 = 50$

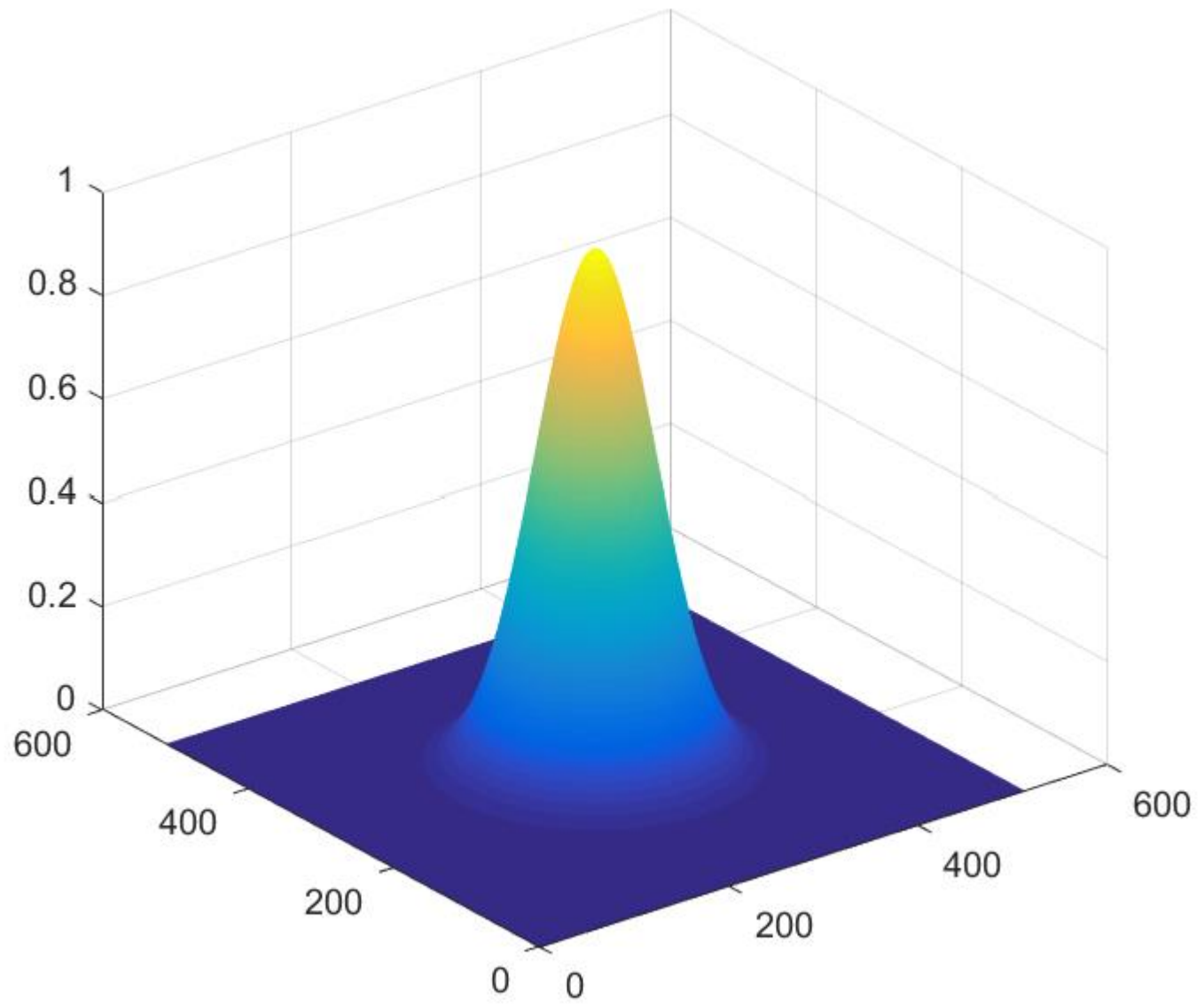

mesh(H)

```

% Penapisan dalam ranah frekuensi dengan Butterworth Lowpass Filter (ILPF)
f=imread('camera.bmp');
imshow(f);
[M,N] = size(f);
%Step 1: Tentukan parameter padding, biasanya untuk citra f(x,y)
%          berukuran M x N, parameter padding P dan Q adalah P = 2M and Q = 2N.
P = 2*M;
Q = 2*N;

%Step 2: Bentuklah citra padding fp(x,y) berukuran P X Q dengan
%          menambahkan pixel-pixel bernilai nol pada f(x, y).
f = im2double(f);
for i = 1:P
    for j = 1:Q
        if i <= M && j<= N
            fp(i,j) = f(i,j);
        else
            fp(i,j) = 0;
        end
    end
end
imshow(f);title('original image');
figure; imshow(fp);title('padded image');

```

```

% Display the Fourier Spectrum
Fc=fftshift(fft2(fp)); % move the origin of the transform to the center of
the frequency rectangle
S2=log(1+abs(Fc)); % use abs to compute the magnitude (handling imaginary)
and use log to brighten display
figure, imshow(S2,[]); title('Fourier spectrum');

%Step 3: Lakukan transformasi Fourier pada fpad(x, y)
F = fft2(double(fp));

%Step 4: Bangkitkan fungsi penapis H berukuran P x Q, misalkan penapis
%yang digunakan adalah Ideal Lowpass Filter (ILPF)

D0 = 50; % cut-off frequency
% Set up range of variables.
u = 0:(P-1);
v = 0:(Q-1);

% Compute the indices for use in meshgrid
idx = find(u > P/2);
u(idx) = u(idx) - P;
idy = find(v > Q/2);
v(idy) = v(idy) - Q;

```

```

% Compute the meshgrid arrays
[V, U] = meshgrid(v, u);
D = sqrt(U.^2 + V.^2);

n = 2;    % default
H = 1./(1 + (D./D0).^(2*n));
H = fftshift(H); figure; imshow(H); title('Butterworth Low Pass Filter');
figure, mesh(H);

%Step 5: Kalikan F dengan H
H = ifftshift(H);
LPF_f = H.*F;

%Step 6: Ambil bagian real dari inverse FFT of G:
LPF_f2=real(ifft2(LPF_f)); % apply the inverse, discrete Fourier transform
figure; imshow(LPF_f2); title('output image after inverse 2D DFT');

%Step 7: Potong bagian kiri atas sehingga menjadi berukuran citra semula
LPF_f2=LPF_f2(1:M, 1:N); % Resize the image to undo padding
figure, imshow(LPF_f2); title('output image');

```

original image



padded image



Fourier spectrum

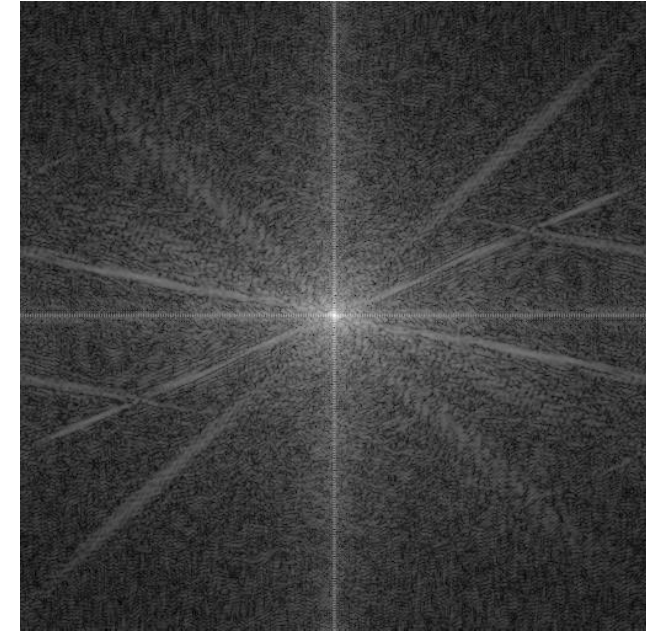

Butterworth Low Pas Filter

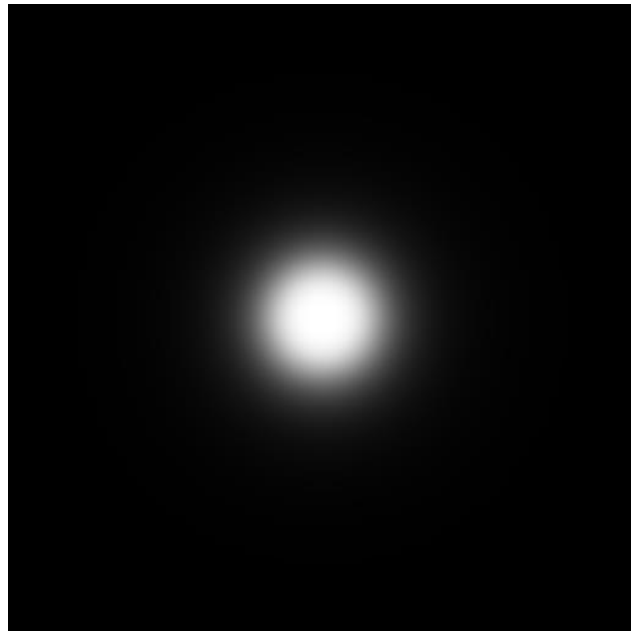

output image after inverse 2D DFT

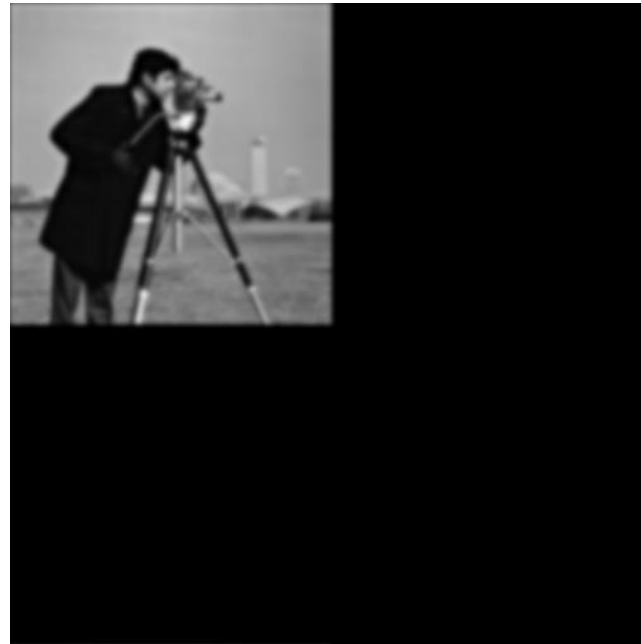

output image

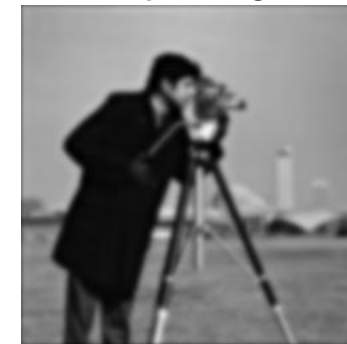

Hasil run program
dengan BLPF, $n = 2$,
 $D_0 = 50$

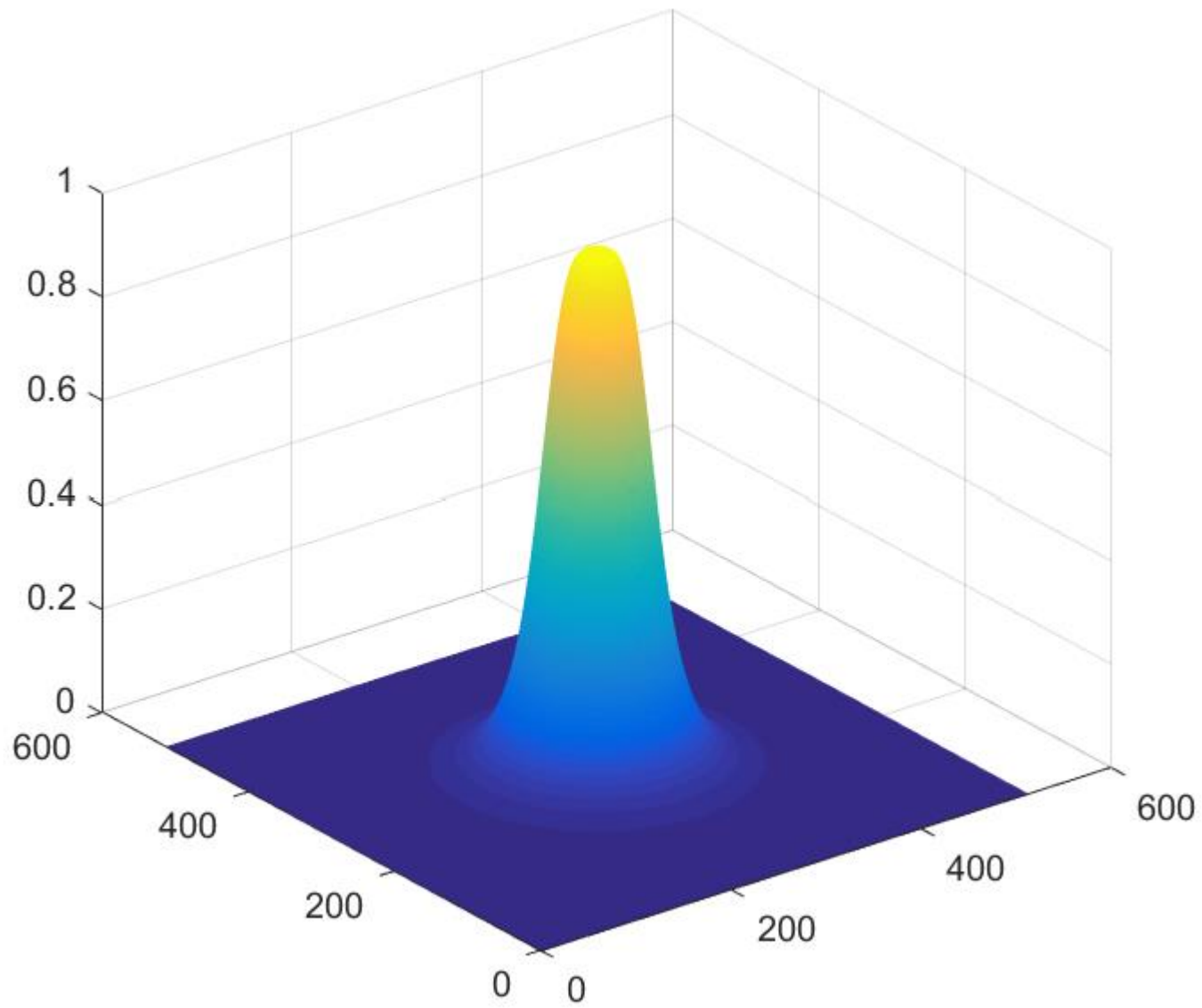

mesh(H)

- Perbandingan hasil

output image



ILPF

output image



GLPF

output image



BLPF

Contoh hasil run pada citra *pepper* dengan Gaussian Low Pass Filter:

original image



padded image

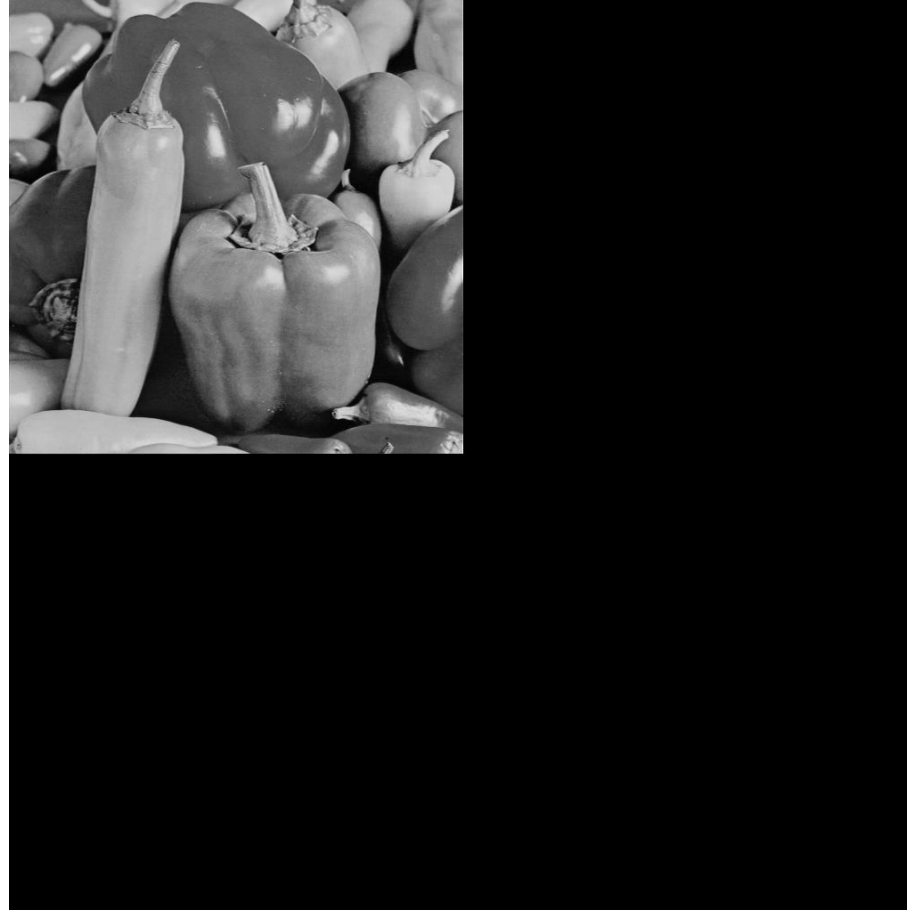

Fourier spectrum

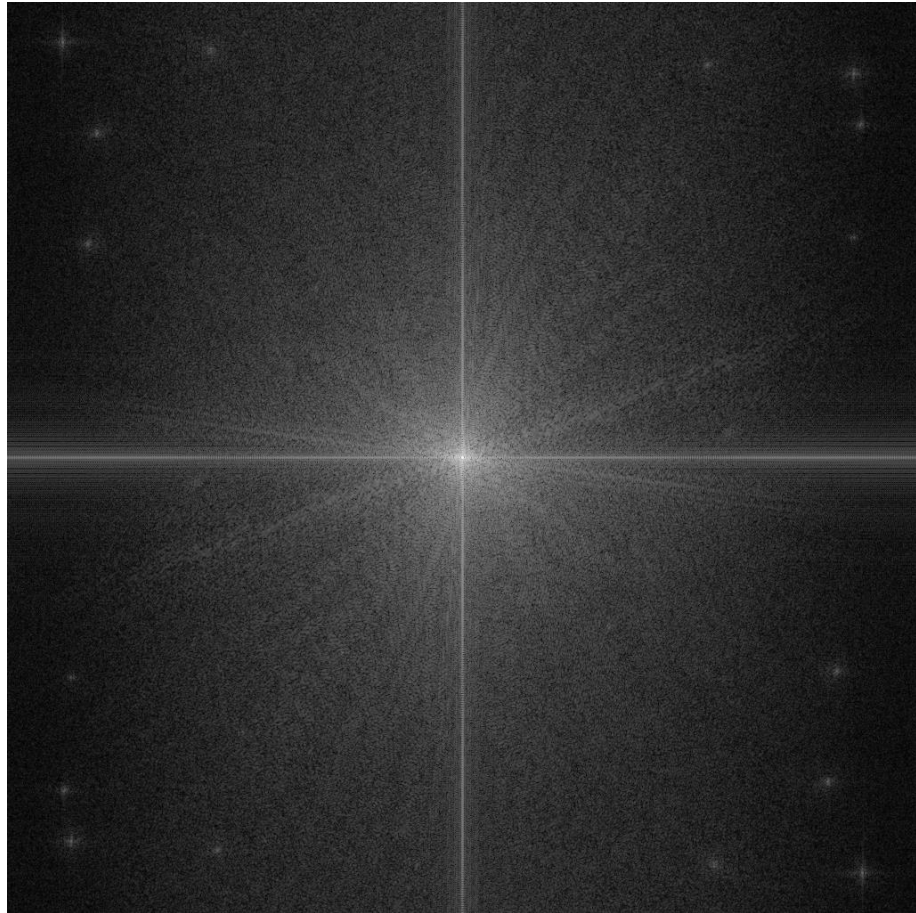

Gaussian Low Pas Filter

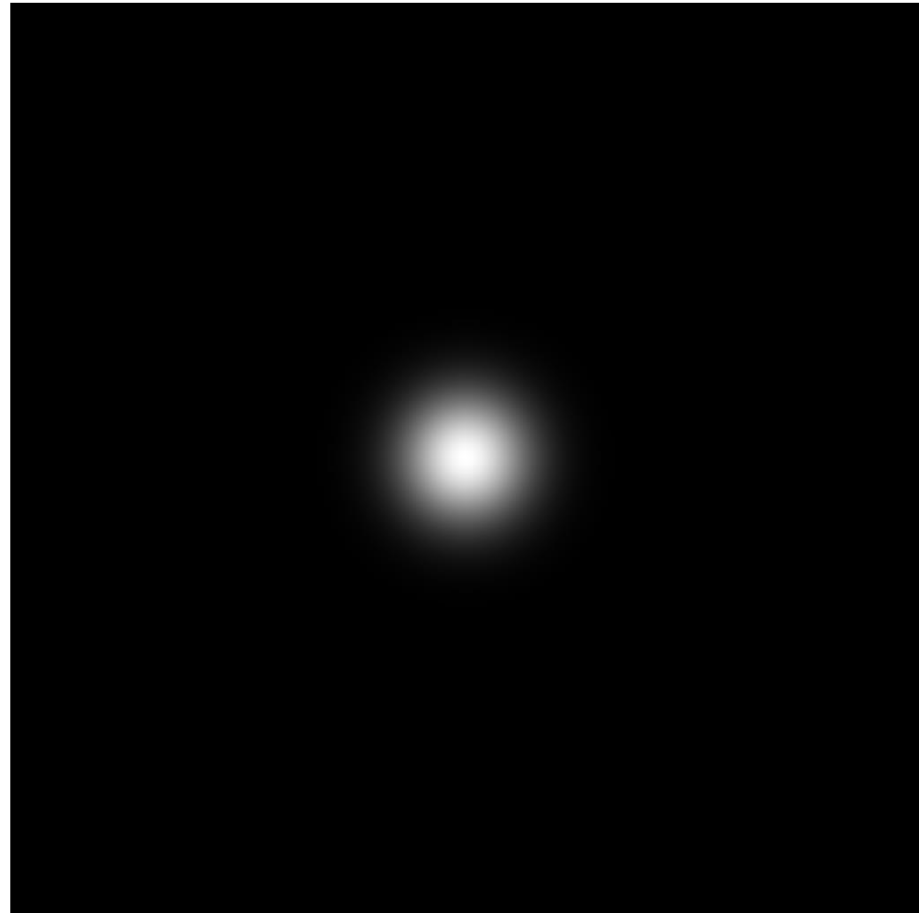

output image after inverse 2D DFT

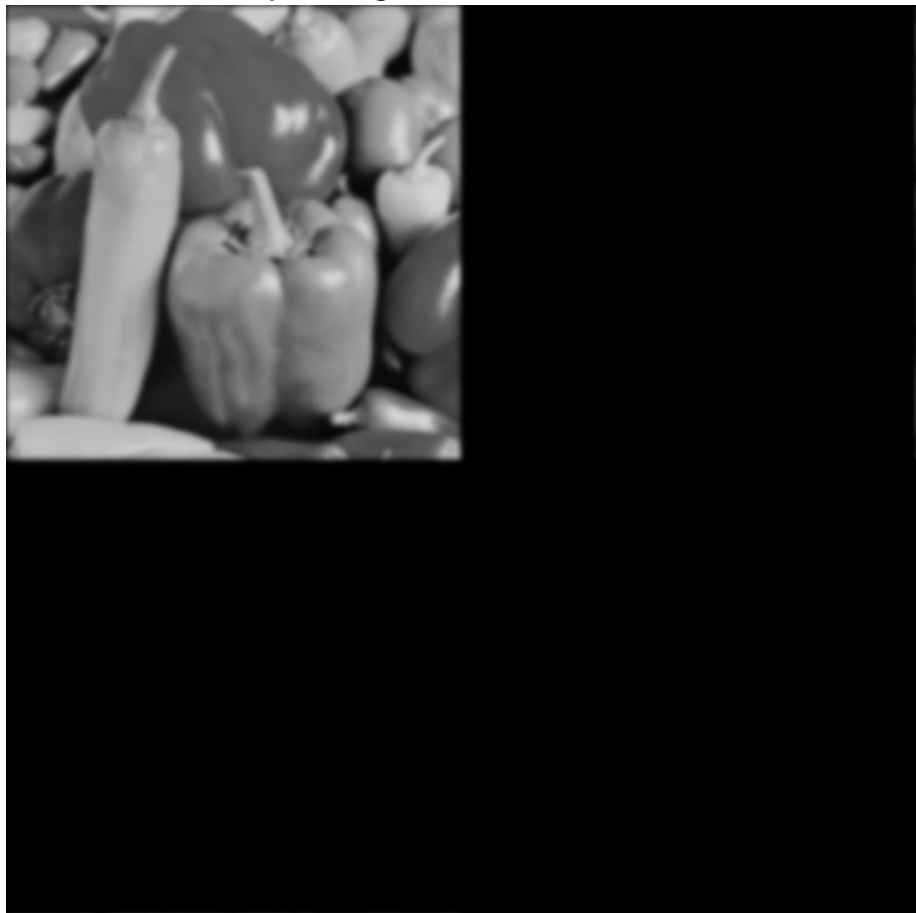

output image



Contoh hasil ILPF

- Menimbulkan efek bergetar (*ringing*) pada citra bluring sebagai karakteristik ILPF
- Akibat dari diskontinuitas pada fungsi penapis

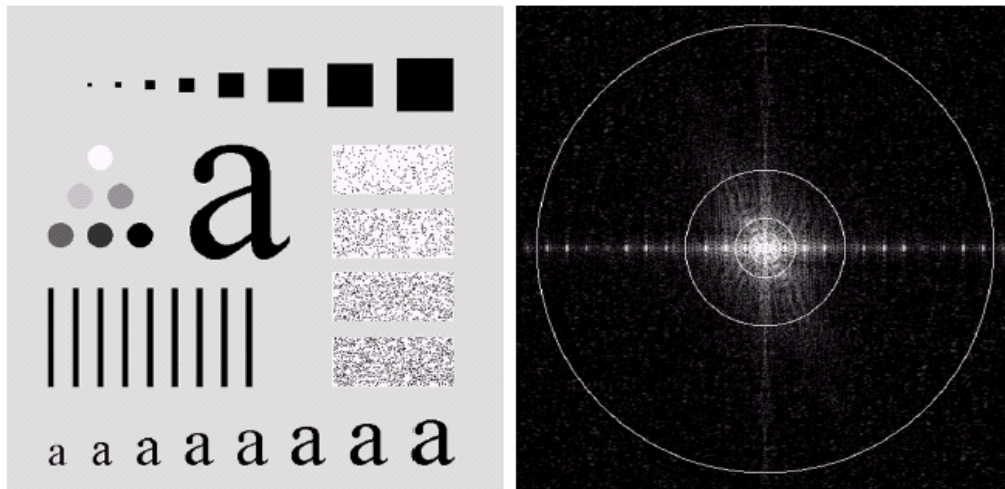

a b

FIGURE 4.11 (a) An image of size 500×500 pixels and (b) its Fourier spectrum. The superimposed circles have radii values of 5, 15, 30, 80, and 230, which enclose 92.0, 94.6, 96.4, 98.0, and 99.5% of the image power, respectively.

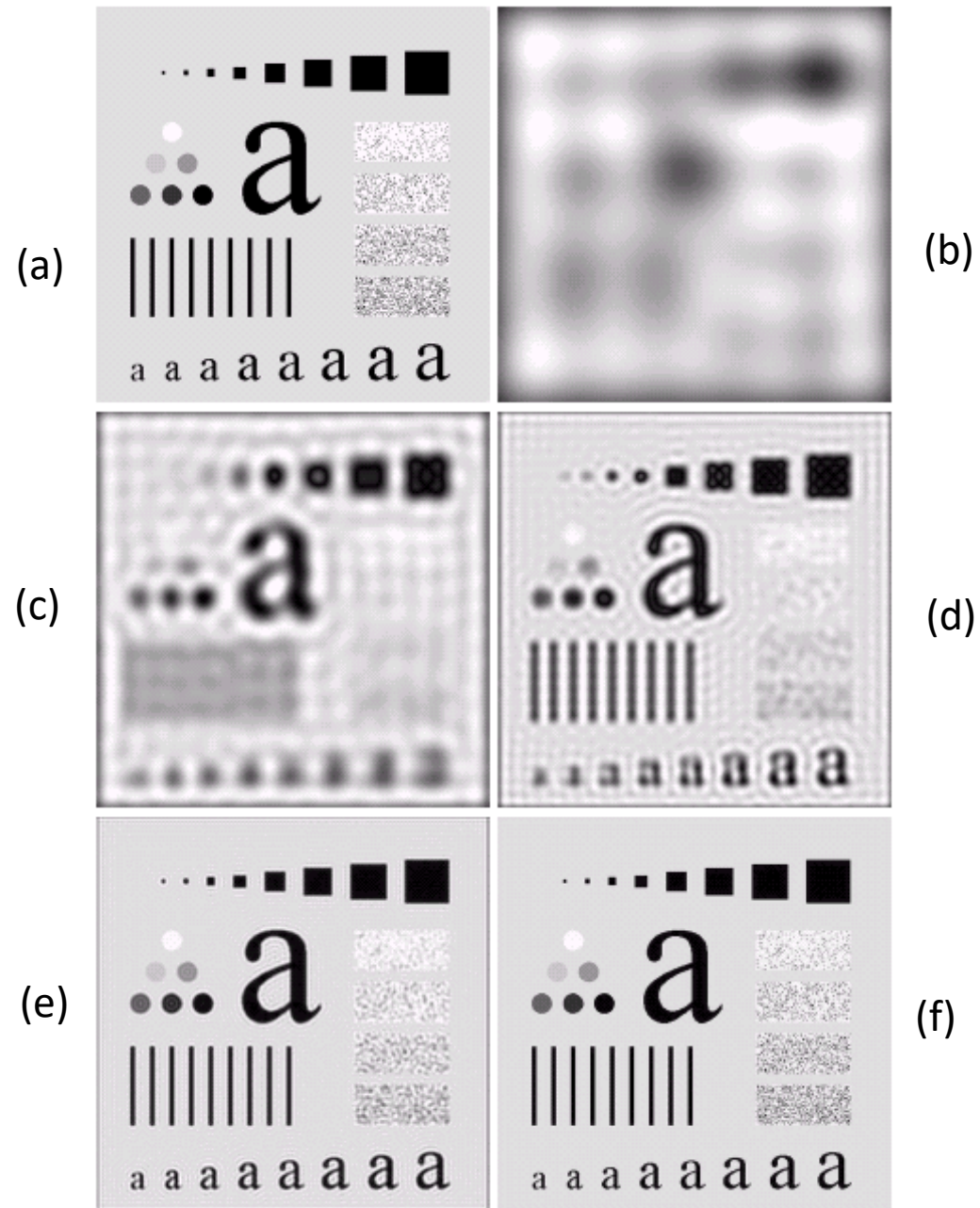

(a) Original image, (b)-(f) Results of ideal lowpass filtering with cutoff frequencies set radii of 5, 15, 30, 80, and 230

Contoh hasil GLPF

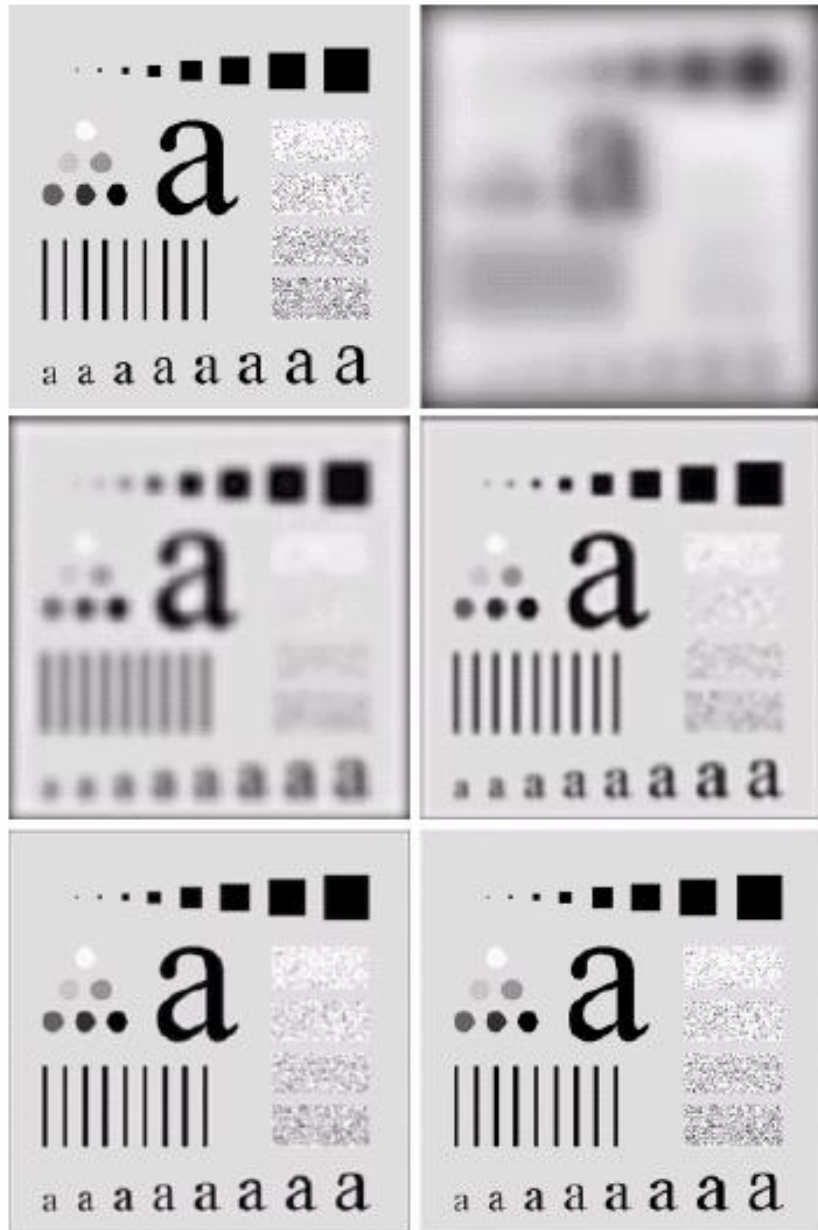

a
b
c
d
e
f

FIGURE 4.15 (a) Original image. (b)–(f) Results of filtering with BLPFs of order 2, with cutoff frequencies at radii of 5, 15, 30, 80, and 230, as shown in Fig. 4.11(b). Compare with Fig. 4.12.

Contoh hasil BLPF

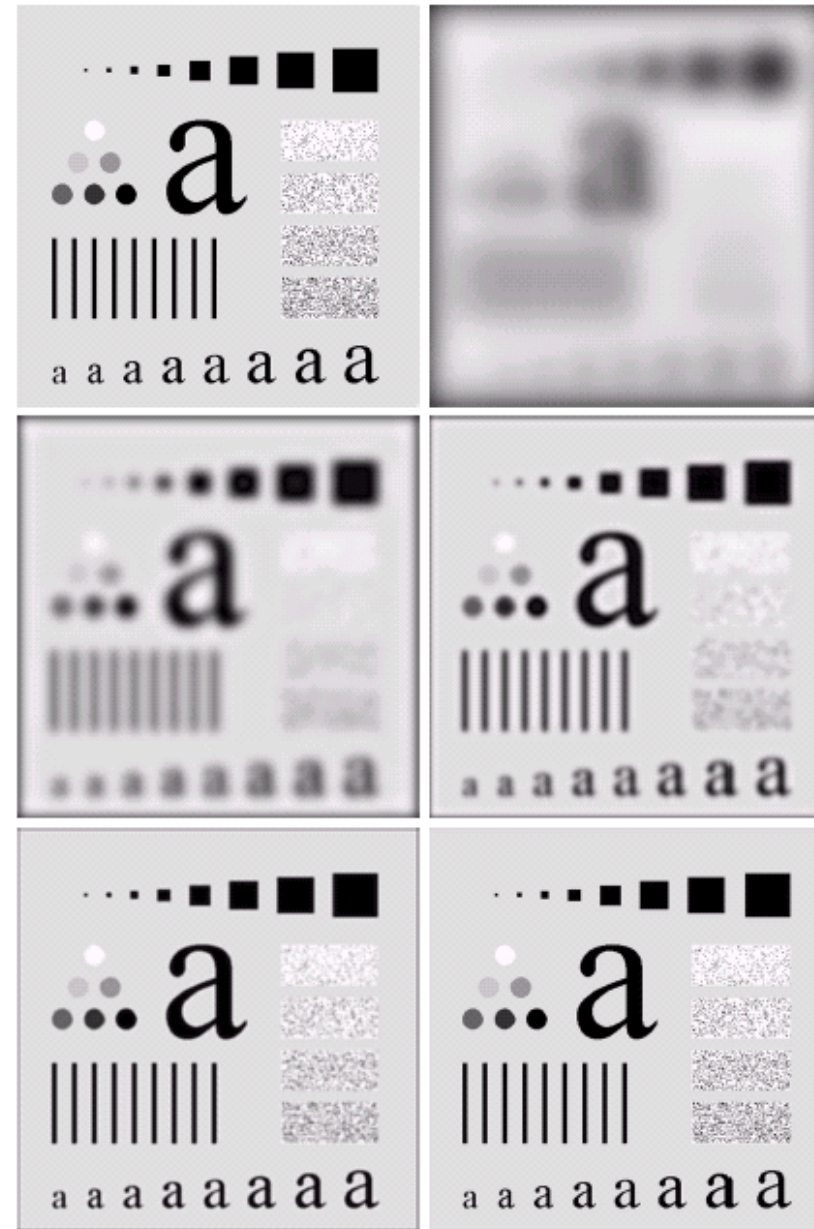

a
b
c
d
e
f

FIGURE 4.15 (a) Original image. (b)–(f) Results of filtering with BLPFs of order 2, with cutoff frequencies at radii of 5, 15, 30, 80, and 230, as shown in Fig. 4.11(b). Compare with Fig. 4.12.

a b

FIGURE 4.19

(a) Sample text of poor resolution (note broken characters in magnified view).
(b) Result of filtering with a GLPF (broken character segments were joined).

Historically, certain computer programs were written using only two digits rather than four to define the applicable year. Accordingly, the company's software may recognize a date using "00" as 1900 rather than the year 2000.

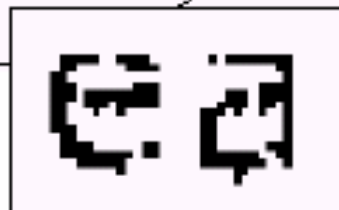

Historically, certain computer programs were written using only two digits rather than four to define the applicable year. Accordingly, the company's software may recognize a date using "00" as 1900 rather than the year 2000.





a b c

FIGURE 4.20 (a) Original image (1028×732 pixels), (b) Result of filtering with a GLPF with $D_0 = 100$, (c) Result of filtering with a GLPF with $D_0 = 80$. Note reduction in skin fine lines in the magnified sections of (b) and (c).



a b c

FIGURE 4.21 (a) Image showing prominent scan lines. (b) Result of using a GLPF with $D_0 = 30$. (c) Result of using a GLPF with $D_0 = 10$. (Original image courtesy of NOAA.)

Highpass filter (HPF) dalam ranah frekuensi

- Penapis lolos tinggi (*highpass filter*) bertujuan menekan komponen berfrekuensi rendah dan meloloskan (sekaligus memperkuat) komponen berfrekuensi tinggi.
- Menghasilkan efek penajaman pada tepi (edge) citra (atau *sharpened image*)
- Hubungan antara penapis lolos tinggi (H_{hp}) dan penapis lolos rendah (H_{lp})

$$H_{hp}(u, v) = 1 - H_{lp}(u, v)$$

- Tiga buah HPF yang utama:
 1. *Ideal highpass filter* (IHPF)
 2. *Butterworth highpass filter* (BHPF)
 3. *Gaussian highpass filter* (GHPF)

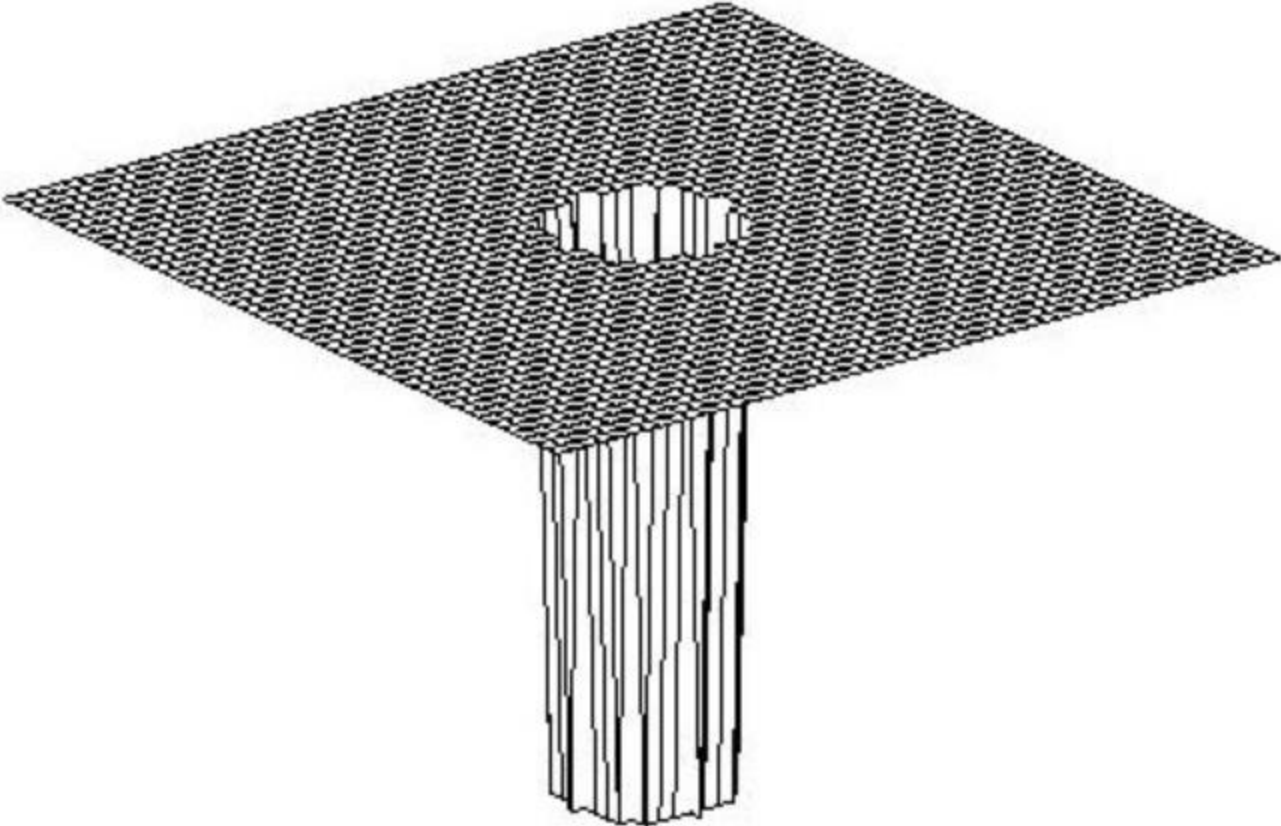
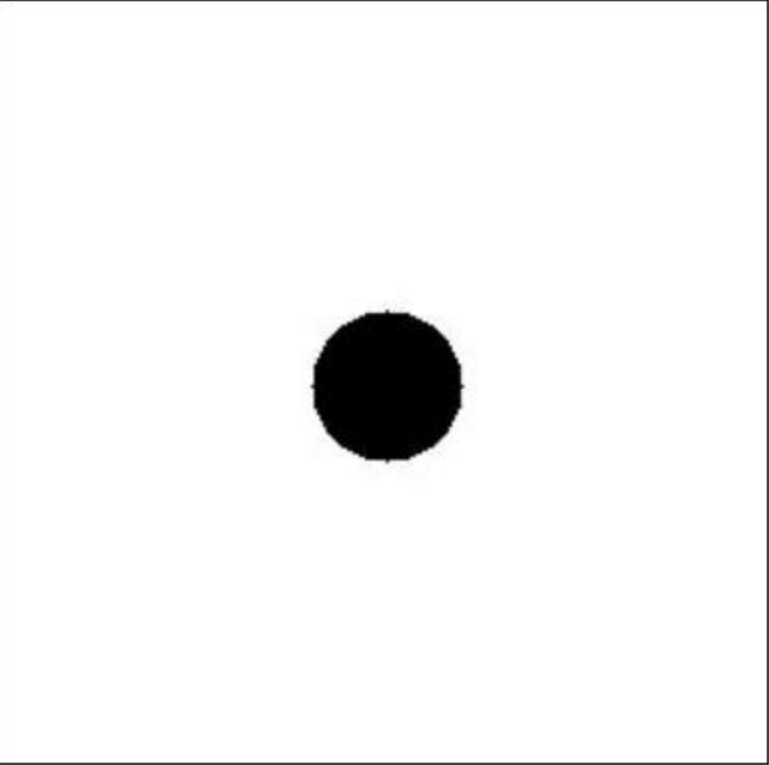
Highpass Filter	Mesh	Image
Ideal		

$$H(u, v) = \begin{cases} 0 & \text{if } D(u, v) \leq D_0 \\ 1 & \text{if } D(u, v) > D_0 \end{cases}$$

Butterworth

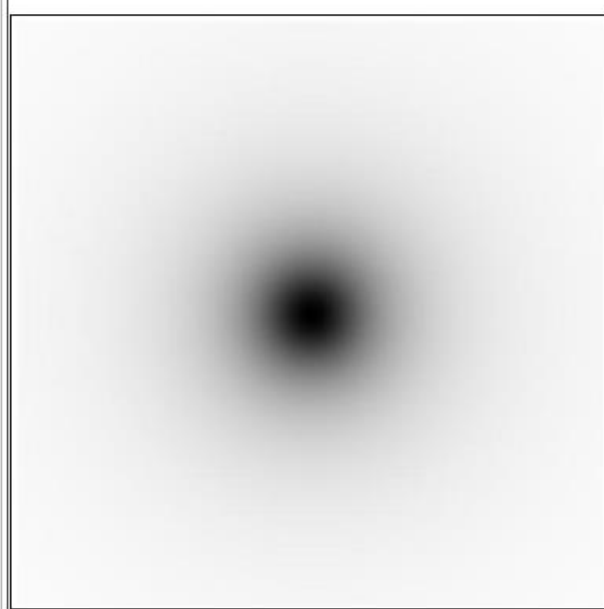
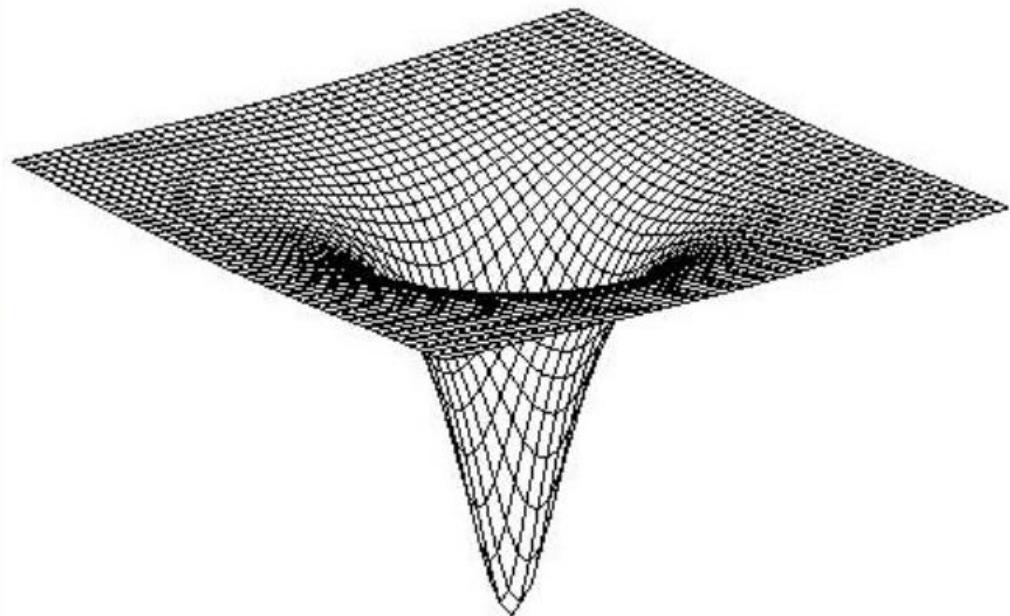

$$H(u, v) = \frac{1}{1 + [D_0/D(u, v)]^{2n}}$$

Gaussian

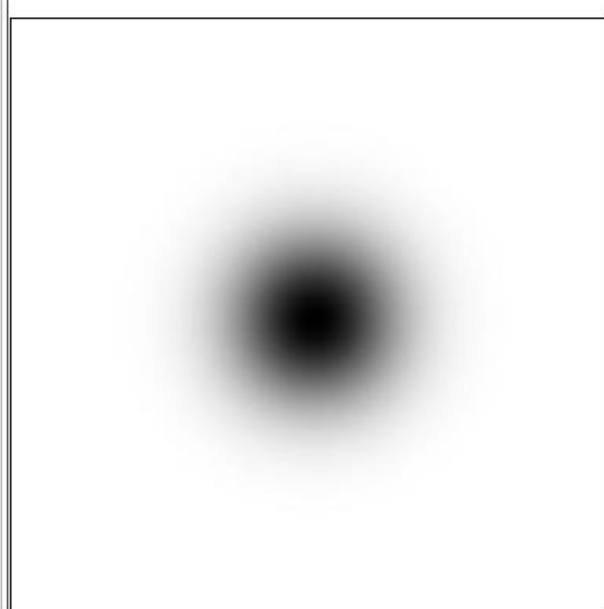
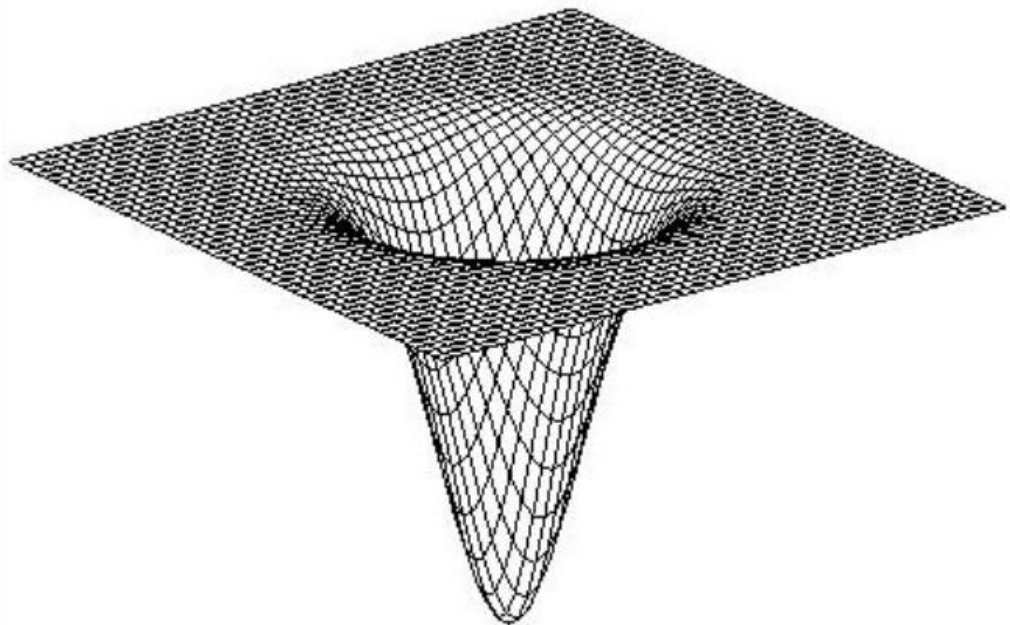

$$H(u, v) = 1 - e^{-D^2(u, v)/2D_0^2}$$

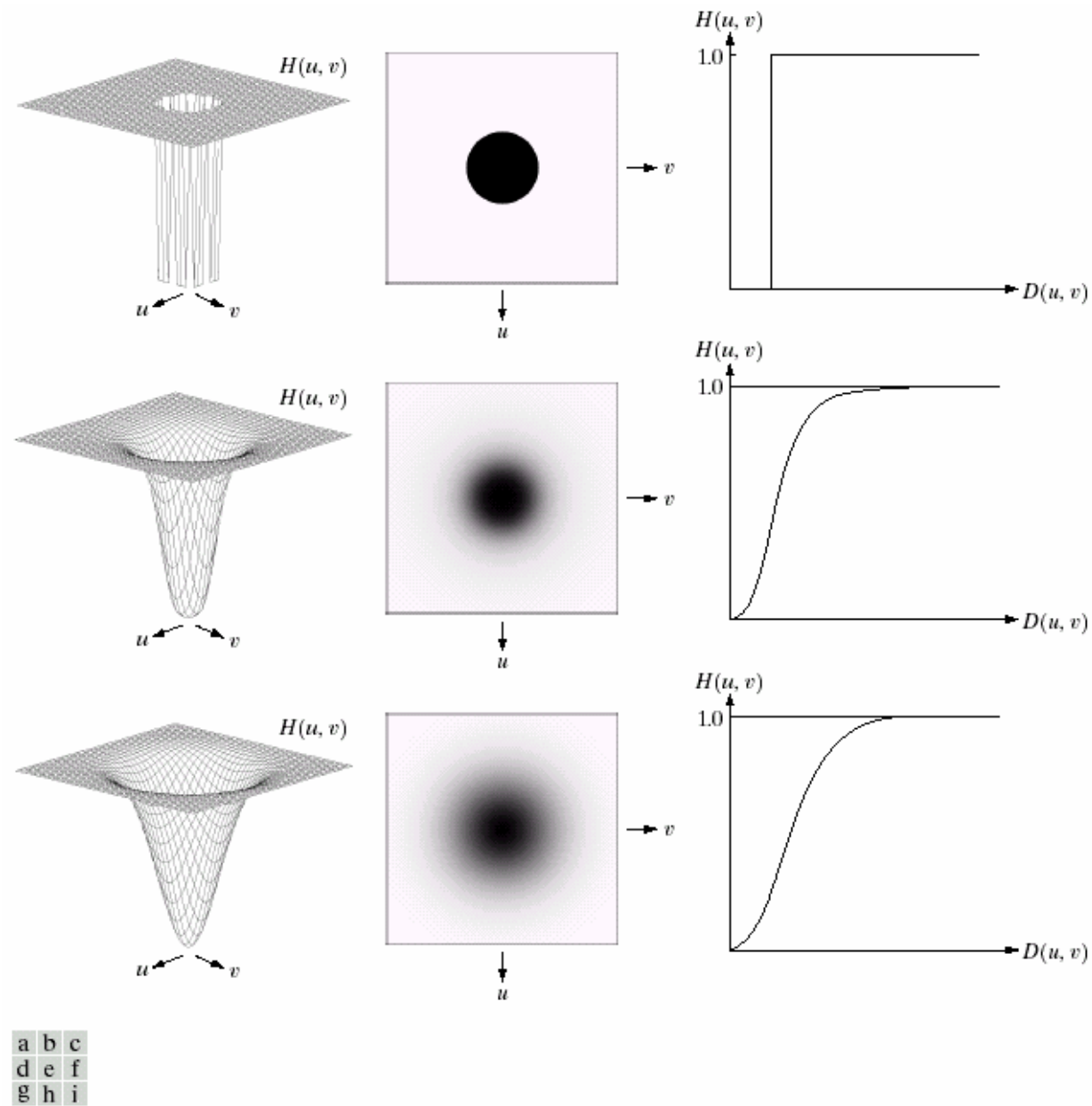

FIGURE 4.22 Top row: Perspective plot, image representation, and cross section of a typical ideal highpass filter. Middle and bottom rows: The same sequence for typical Butterworth and Gaussian highpass filters.

Representasi Spasial Ideal, Butterworth dan Gaussian Highpass Filter

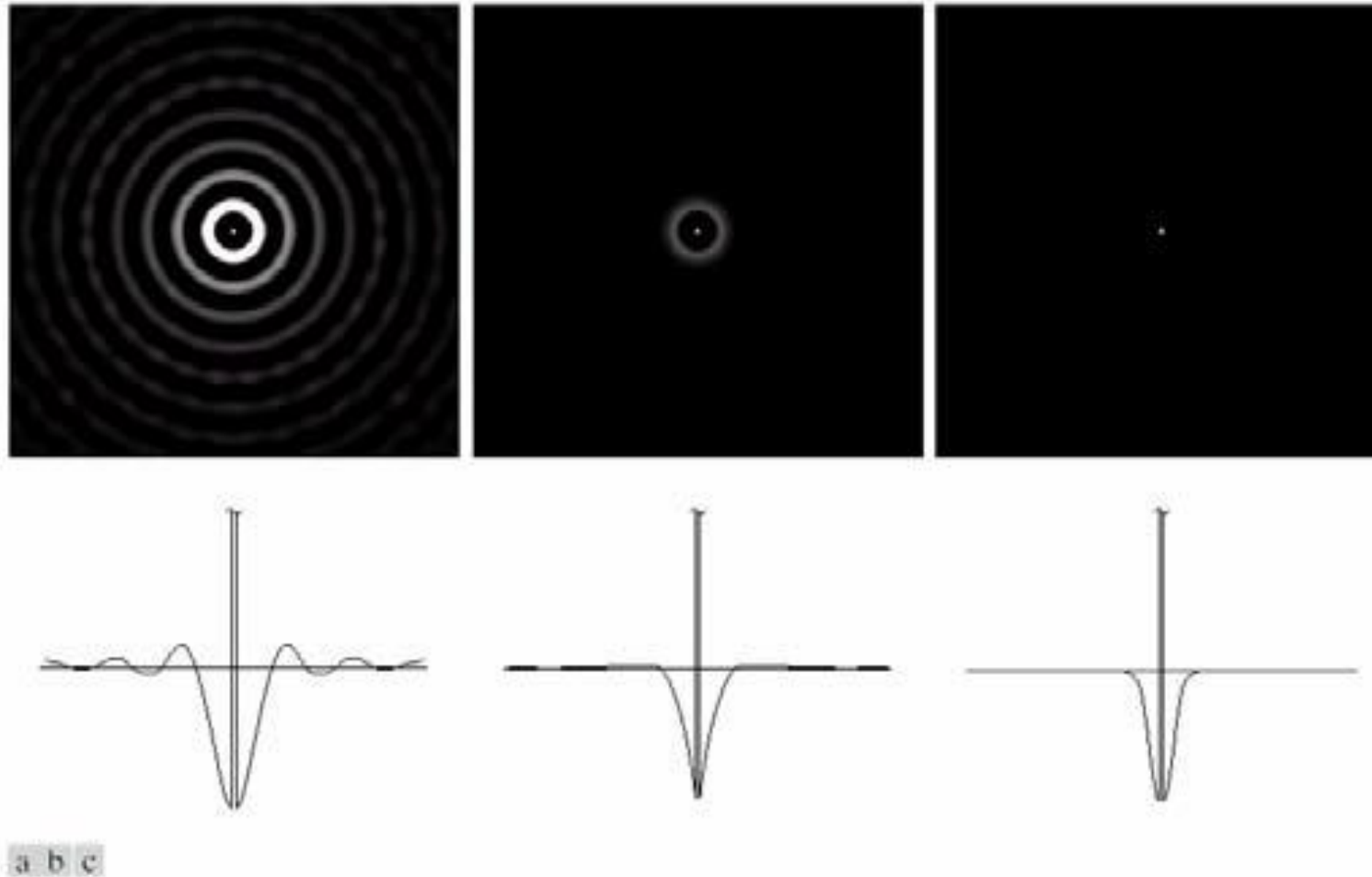

FIGURE 4.23 Spatial representations of typical (a) ideal, (b) Butterworth, and (c) Gaussian frequency domain highpass filters, and corresponding gray-level profiles.

```

% Penapisan dalam ranah frekuensi dengan highpass filter
f=imread('camera.bmp');
imshow(f);
[M,N] = size(f);
%Step 1: Tentukan parameter padding, biasanya untuk citra f(x,y)
%         berukuran M x N, parameter padding P dan Q adalah P = 2M and Q = 2N.
P = 2*M;
Q = 2*N;

%Step 2: Bentuklah citra padding fp(x,y) berukuran P X Q dengan
%         menambahkan pixel-pixel bernilai nol pada f(x, y).
f = im2double(f);
for i = 1:P
    for j = 1:Q
        if i <= M && j<= N
            fp(i,j) = f(i,j);
        else
            fp(i,j) = 0;
        end
    end
end
imshow(f);title('original image');
figure; imshow(fp);title('padded image');

```

```

%Step 3: Lakukan transformasi Fourier pada fpad(x, y)
F = fft2(double(fp));

%Step 4: Bangkitkan fungsi penapis H berukuran P x Q, misalkan penapis
%yang digunakan adalah penapis Gaussian
D0 = 0.05*P;
% Set up range of variables.
u = 0:(P-1);
v = 0:(Q-1);

% Compute the indices for use in meshgrid
idx = find(u > P/2);
u(idx) = u(idx) - P;
idy = find(v > Q/2);
v(idy) = v(idy) - Q;

% Compute the meshgrid arrays
[V, U] = meshgrid(v, u);
D = sqrt(U.^2 + V.^2);

% Calculate the HPF Gaussian
H = exp(-(D.^2)./(2*(D0^2)));
H = 1 - H;
figure;imshow(H);title('HPF Gaussian Mask');

```



```

%Step 5: Kalikan F dengan H
LPF_f = H.*F;

%Step 6: Ambil bagian real dari inverse FFT of G:
HPF_f2=real(ifft2(HPF_f)); % apply the inverse, discrete Fourier transform
figure; imshow(HPF_f2);title('output image after inverse 2D DFT');

%Step 7: Potong bagian kiri atas sehingga menjadi berukuran citra semula
HPF_f2=HPF_f2(1:M, 1:N); % Resize the image to undo padding
figure, imshow(HPF_f2); title('output image');

% Display the Fourier Spectrum
Fc=fftshift(fft2(fp)); % move the origin of the transform to the center of
the frequency rectangle
S2=log(1+abs(Fc)); % use abs to compute the magnitude (handling imaginary)
and use log to brighten display
figure, imshow(S2,[]); title('Fourier spectrum');

```

original image



padded image



Fourier spectrum

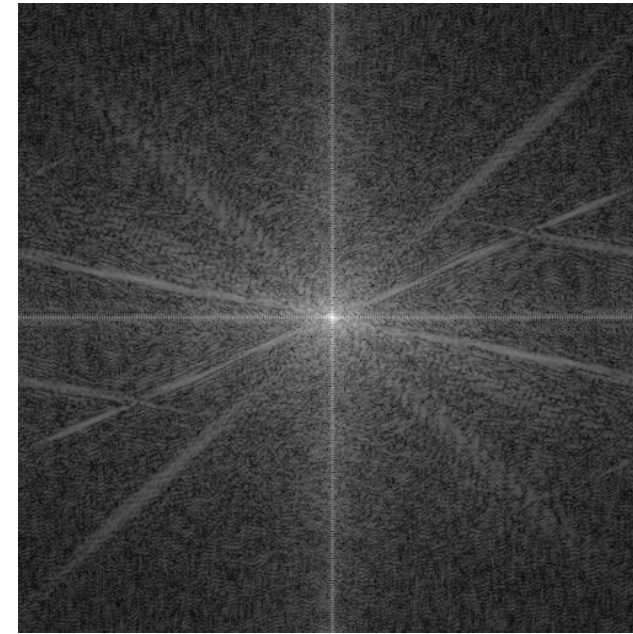

Gaussian High Pas Filter

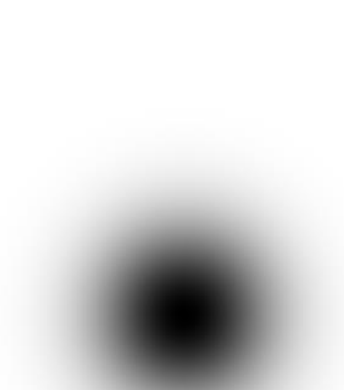

output image after inverse 2D DFT



output image



Hasil run program
dengan GHPF, $D_0 = 50$

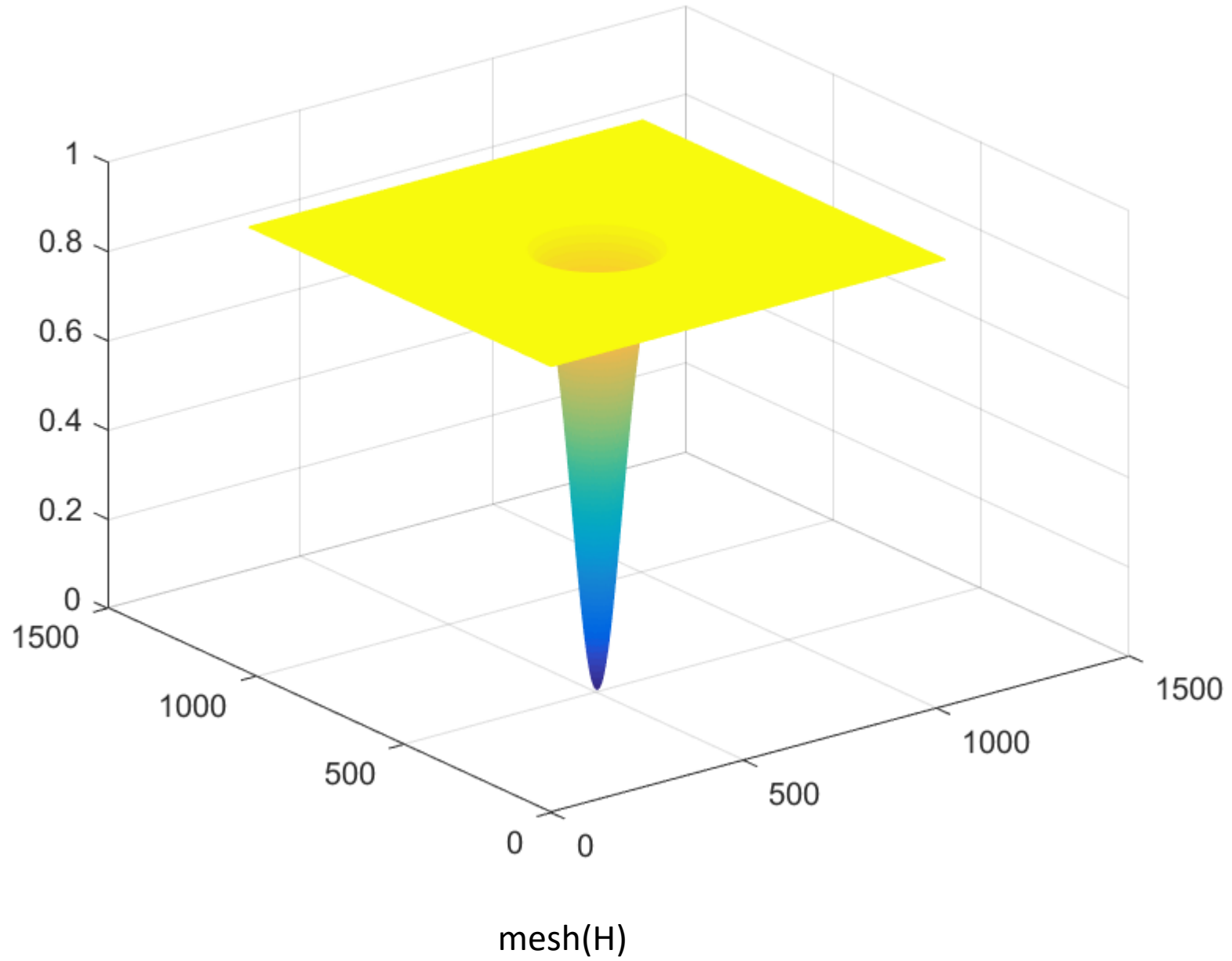

Contoh hasil lain dengan citra *pepper*:

original image



padded image

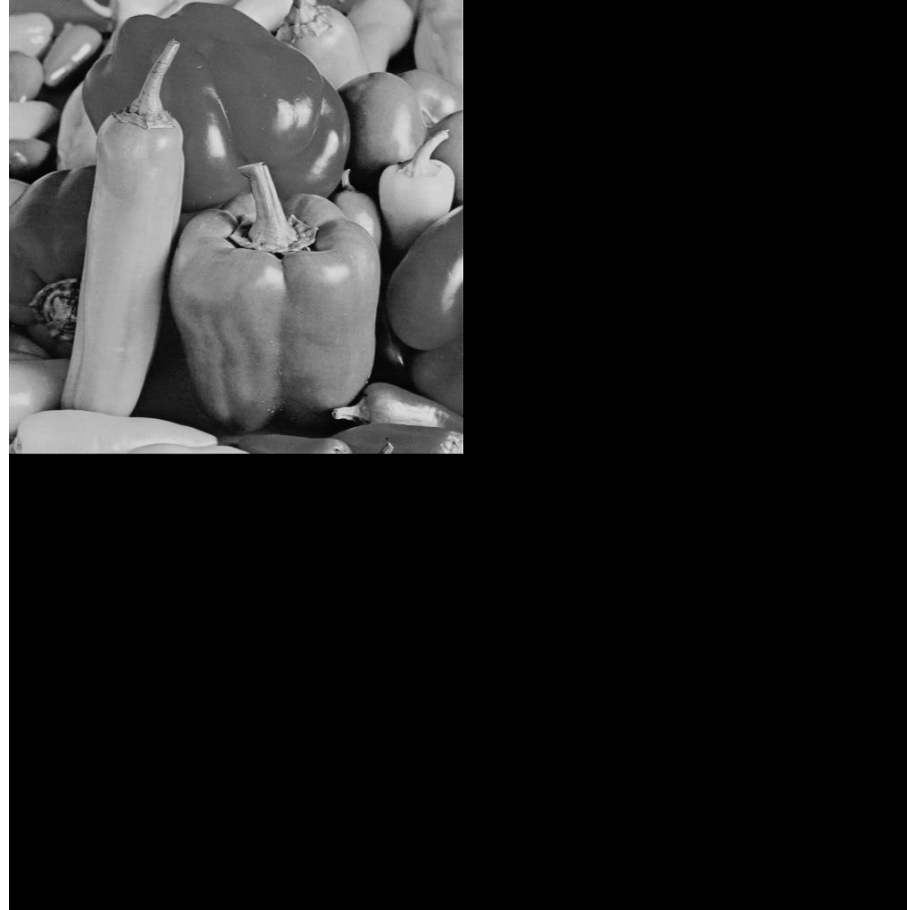

Fourier spectrum

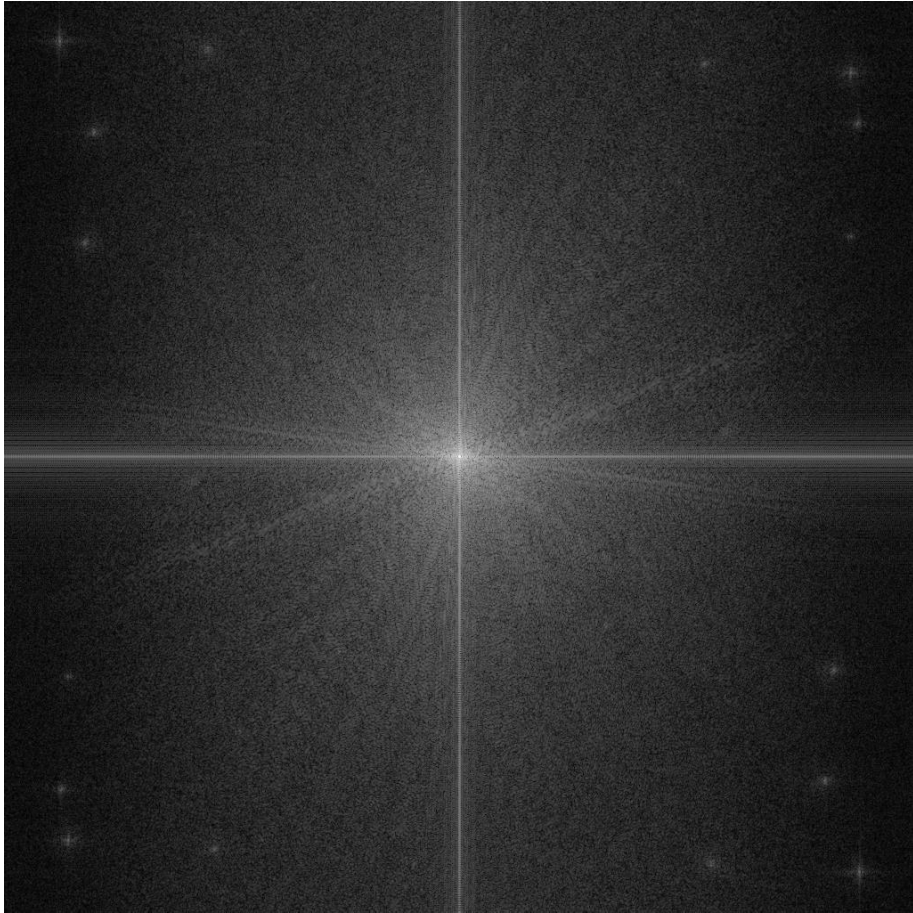

Gaussian High Pas Filter

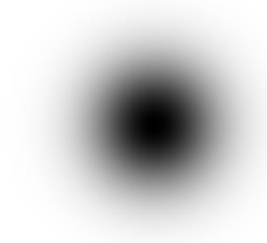

output image after inverse 2D DFT



output image



Example: result of IHPF

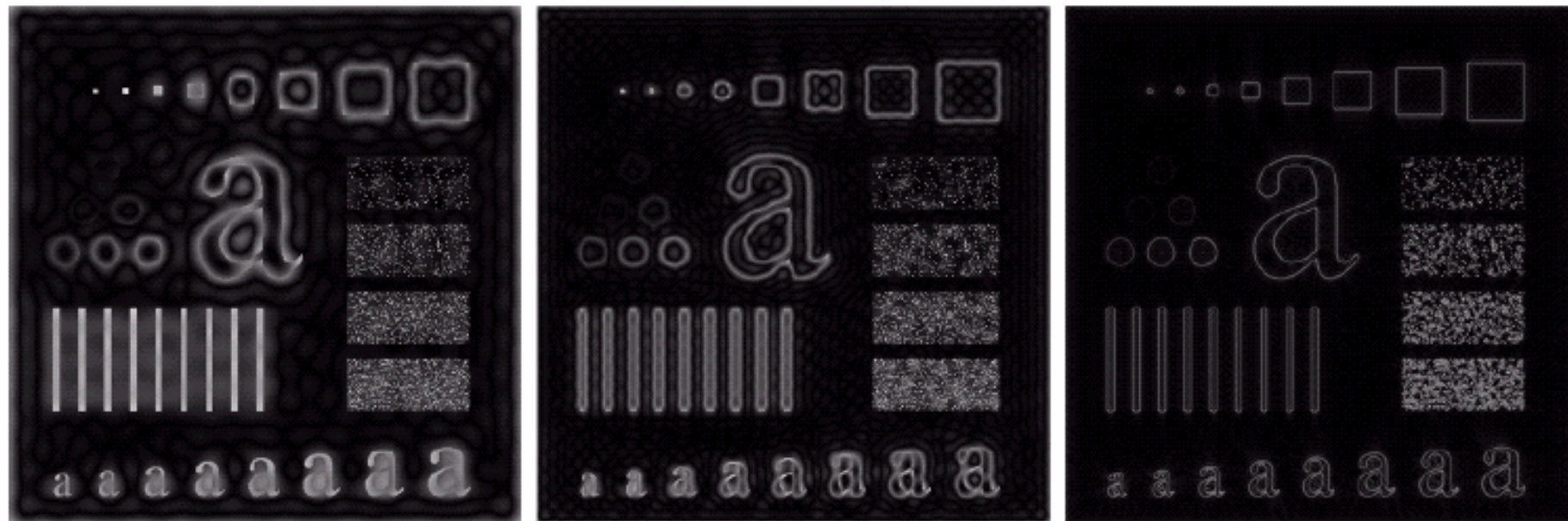

a b c

FIGURE 4.24 Results of ideal highpass filtering the image in Fig. 4.11(a) with $D_0 = 15, 30,$ and $80,$ respectively. Problems with ringing are quite evident in (a) and (b).

Example: result of BHPF

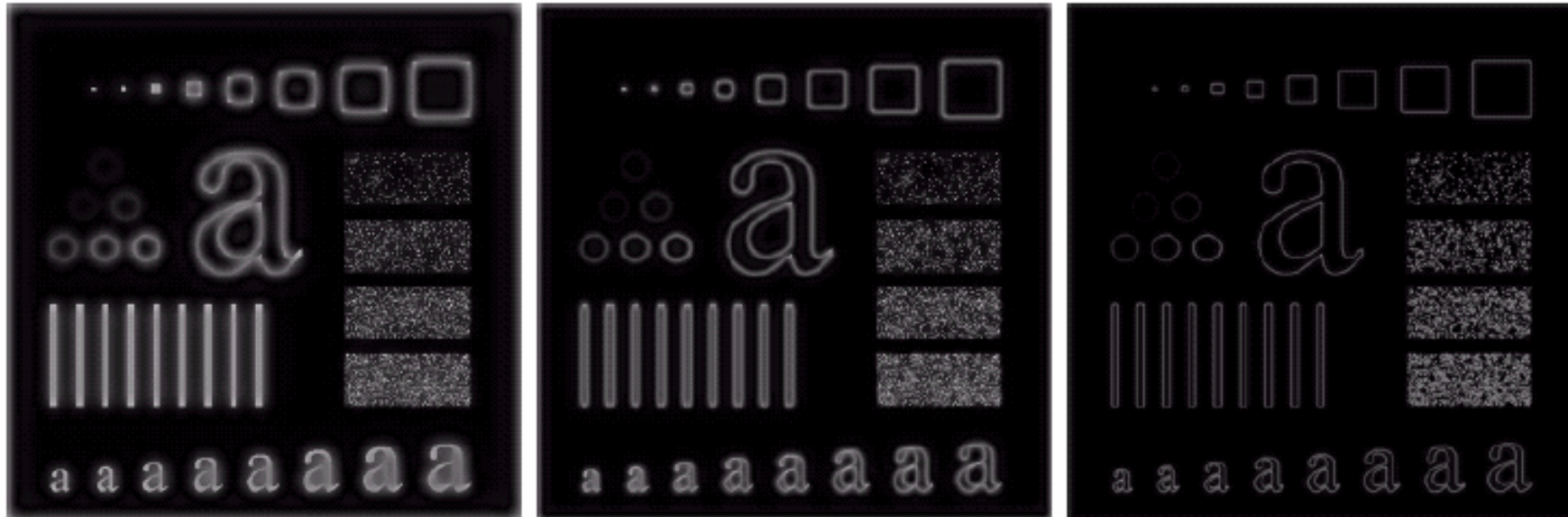

a b c

FIGURE 4.25 Results of highpass filtering the image in Fig. 4.11(a) using a BHPF of order 2 with $D_0 = 15$, 30, and 80, respectively. These results are much smoother than those obtained with an ILPF.

Example: result of GHPF

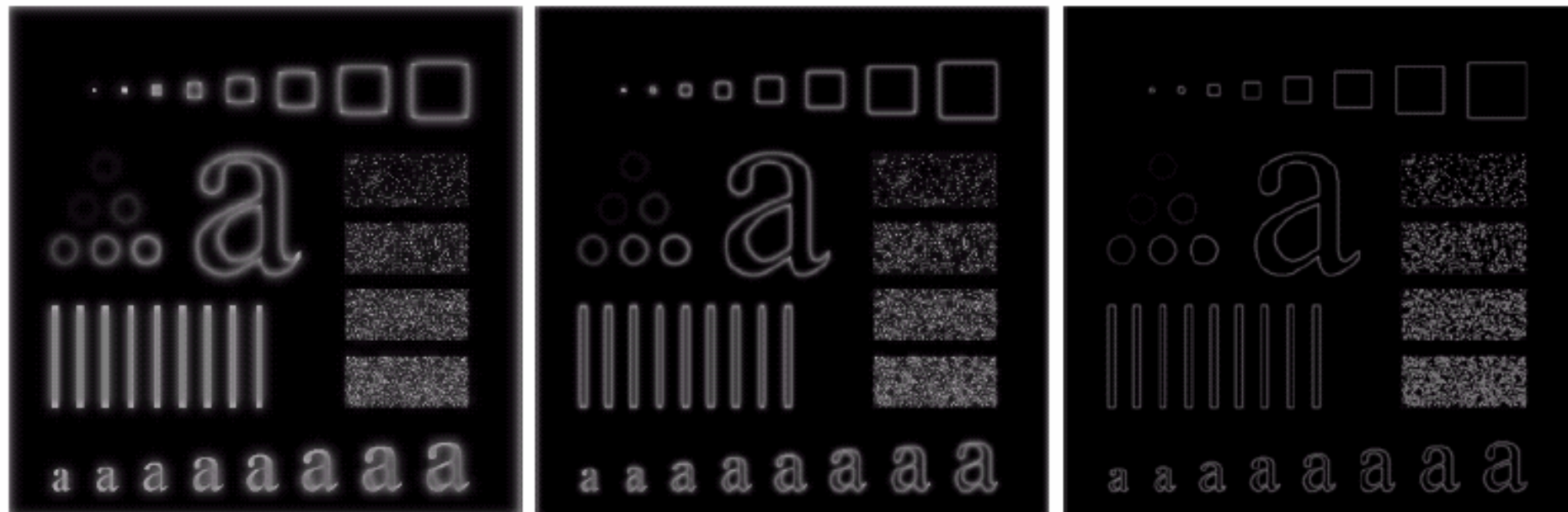

a b c

FIGURE 4.26 Results of highpass filtering the image of Fig. 4.11(a) using a GHPF of order 2 with $D_0 = 15$, 30, and 80, respectively. Compare with Figs. 4.24 and 4.25.

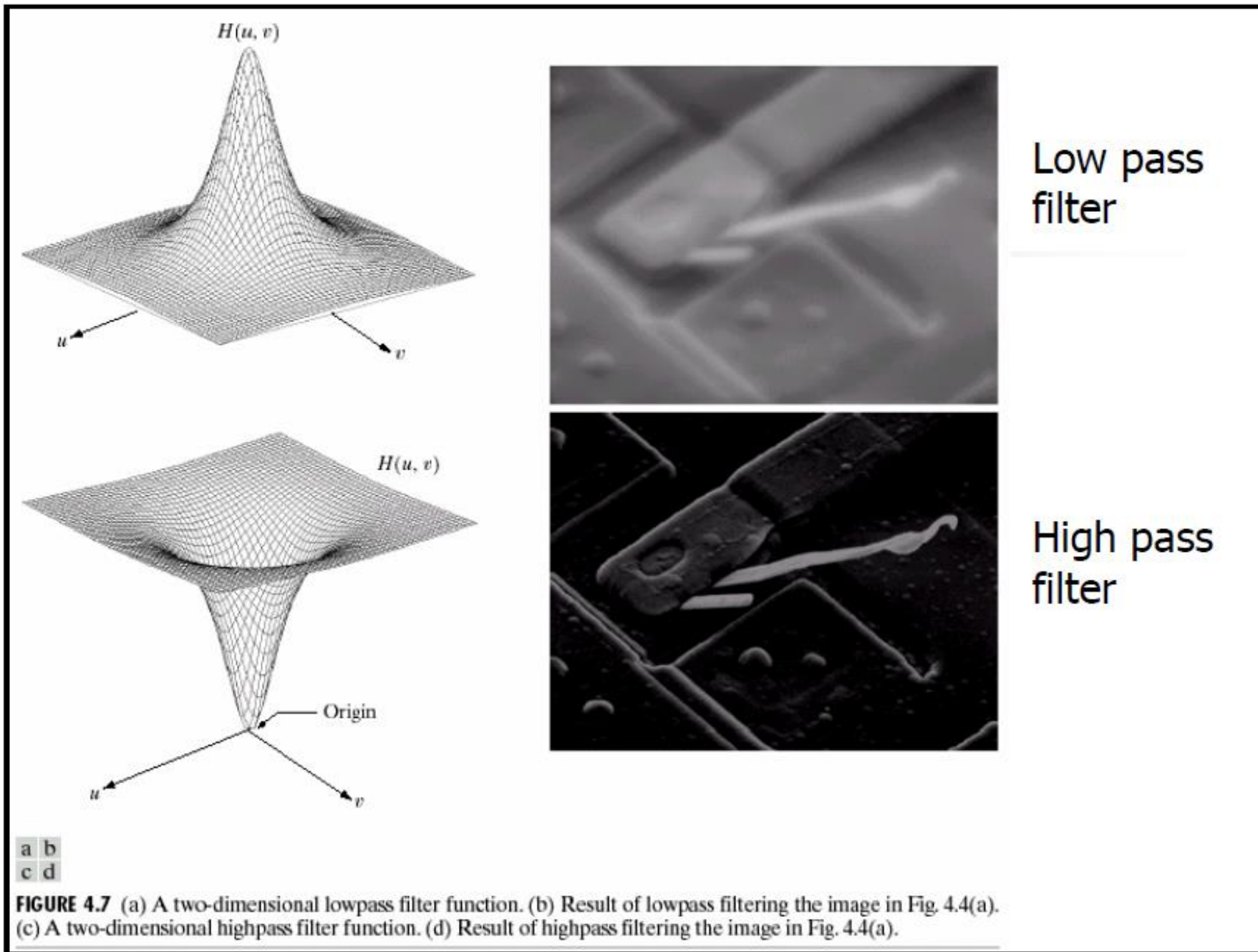

a b
c d

FIGURE 4.7 (a) A two-dimensional lowpass filter function. (b) Result of lowpass filtering the image in Fig. 4.4(a). (c) A two-dimensional highpass filter function. (d) Result of highpass filtering the image in Fig. 4.4(a).

Notch Filter: Membuang nilai rata-rata di dalam citra

$$H(u, v) = \begin{cases} 0 & \text{if } (u, v) = (M/2, N/2) \\ 1 & \text{otherwise} \end{cases}$$

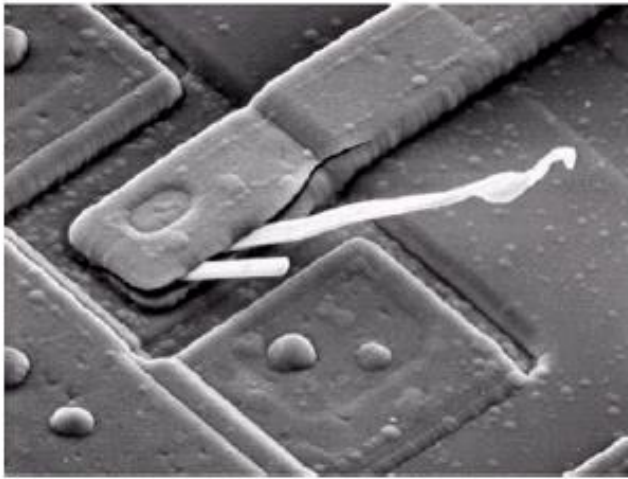

a
b

FIGURE 4.4
(a) SEM image of a damaged integrated circuit.
(b) Fourier spectrum of (a). (Original image courtesy of Dr. J. M. Hudak, Brockhouse Institute for Materials Research, McMaster University, Hamilton, Ontario, Canada.)

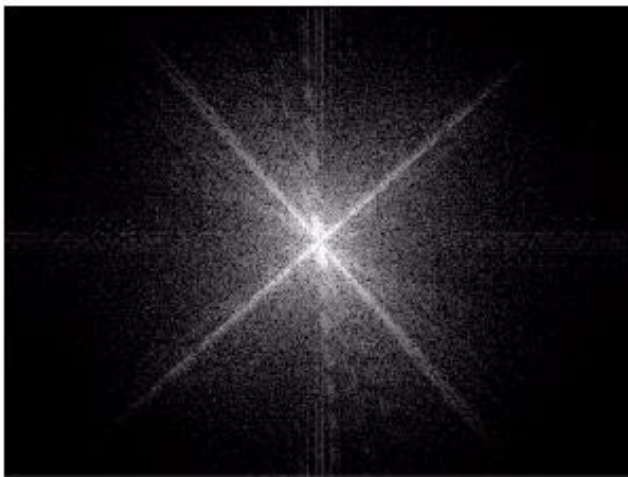

Note: $F(0,0)$ is equal to MN times the average value of $f(x,y)$

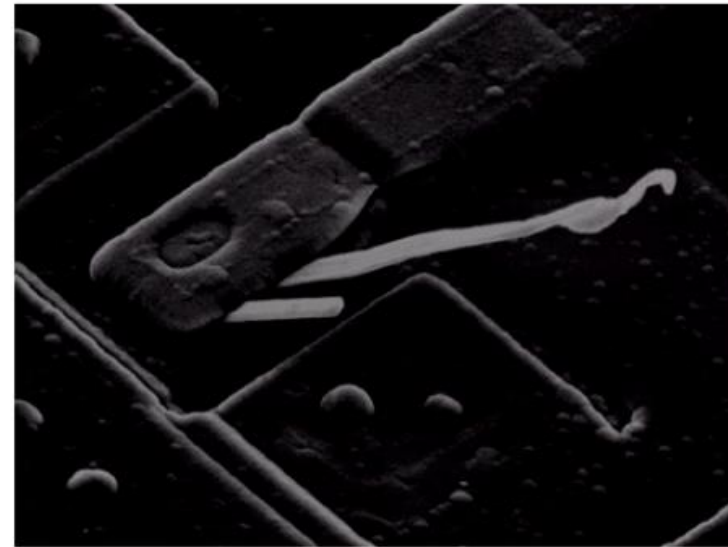

FIGURE 4.6
Result of filtering the image in Fig. 4.4(a) with a notch filter that set to 0 the $F(0, 0)$ term in the Fourier transform.

Unsharp Masking dan High-Boost Filtering dalam Ranah Frekuensi

- **Unsharp Masking:** $f_s(x, y) = f(x, y) - f_{lp}(x, y)$

$$F_s(u, v) = F(u, v) - F_{lp}(u, v) = \underbrace{(1 - H_{lp}(u, v))}_{H_{hp}(u, v)} F(u, v)$$

- **High-Boost Filtering:** $f_{hb}(x, y) = Af(x, y) - f_{lp}(x, y)$
($A \geq 1$)

$$\begin{aligned} F_{hb}(u, v) &= AF(u, v) - F_{lp}(u, v) = \\ &= (A - H_{lp}(u, v))F(u, v) = (A - 1 + H_{hp}(u, v))F(u, v) \end{aligned}$$